

**IMPACT OF EDUCATIONAL ROBOTIC ACTIVITIES ON SECONDARY  
SCHOOL STUDENTS' INTEREST IN ENGINEERING CAREER  
PATHWAYS**

**Peter Ngugi Mwangi**

**A Thesis Submitted in Partial Fulfilment of the Requirements for the Degree of  
Doctor of Philosophy in Technology Education (Electrical and Electronics  
Option) of Murang'a University of Technology**

**November, 2022**

## DECLARATION

I hereby declare that this thesis is my original work and to the best of my knowledge has not been presented for a degree award in this or any other university.

---

Peter Ngugi Mwangi

---

Date

TE500/5068/2018

## APPROVAL

The undersigned certify that they have read and hereby recommend for acceptance of Murang'a University of Technology a thesis entitled "**Impact of Educational Robotic Activities on Secondary School Students' Interest in Engineering Career Pathways.**"

---

Prof. Eng. Christopher Maina Muriithi, PE

---

Date

Department of Electrical and Electronics Engineering

Murang'a University of Technology

---

Dr. Peace Byrne Agufana,

---

Date

Department of Education and Technology,

Murang'a University of Technology.

## **DEDICATION**

This thesis is dedicated to Purity; my lovely wife; and our children, Precious, Peniel and Prosper; for their support, understanding, encouragement and prayers. Finally, to all the members of my family and friends who were very instrumental in my entire course.

## **ACKNOWLEDGMENT**

First and foremost, I take this opportunity to express my sincere gratitude to the Almighty God for His protection, peace, good health, intellectual blessing and financial provision to undertake this study. Secondly, I am very thankful to my supervisors; Prof. Eng. Christopher Maina, PhD and Dr. Peace Agufana, PhD for their scholarly advice and timely feedback on my work every time I presented it to them for direction. Indeed, I will be forever grateful for your inspiration and dedication to my work whenever I needed your guidance. I also appreciate the Technologists, Technicians, and the students in Bachelor of Technology and Bachelor of Technology Education who all participated actively and endeavored to make the workshop organized at Murang'a university of Technology successful. I acknowledge the funding of the research activities by the Royal Academy of Engineering, through the grant titled "Where engineering skills matter most". I also wish to acknowledge the Murang'a University of Technology fraternity, colleagues and lecturers in the department of Education and technology for the moral support and advice. I appreciate the administration and parents of the schools that participated in this Study. I also acknowledge the Murang'a County Director of Education for giving me permission to conduct this research in Kangema Sub-County. Finally, I want to acknowledge my wife, Purity; my children, Precious and Peniel; for your prayers, understanding, care, support and patience throughout the period of this study.

## ABSTRACT

Science, Technology, Engineering and Mathematics related careers are important in preparing any nation for development. There has been low interest by the secondary school students in the STEM fields and as such teaching and learning in these areas must be reconsidered. It is important develop activities and integrate them in these subjects in order to expose the students to Engineering and afterwards assess the impact of the exposure to the interest in these subjects. Some of the activities that could be developed and implemented include educational robotic activities. Most of the existing educational robots are expensive and are not affordable to most of the public secondary schools in the developing countries. In this study two low cost robots were designed for purposes of education which included robotic car and a robotic arm. This was followed by development of robotic activities based on the robots, integration of the activities to Physics and Mathematics and the assessment of the impact of the integrated activities to learning of the subjects and choice of a career pathways towards Engineering. This research was guided by constructivism and constructionism theories. A mixed methods research design was adopted in this study. The research was conducted in secondary schools in Kangema Sub-county, Murang'a County in Kenya. The target population included 2,478 Form 2 students where 270 students were selected through simple random sampling method. The selected students were introduced to the educational robots and robotic related activities. A questionnaire, a pre-test and post-test examinations and an interview schedule were used to collect data. Quantitative data was analyzed using descriptive statistics such as frequencies, percentages and measures of central tendency which comprised of the mean and standard deviation. Inferential statistics was also used in analyzing the quantitative data, specifically sign test, paired sample t-test, correlation, Chi-Square test and One-Way ANOVA. From this study, a low-cost robotic kit was designed and developed by adopting locally available materials and readily available programs that are simple to understand and modify. Precollege robotic activities that were divisible into simple tasks were developed based on the designed kit. The developed robotic activities were integrated into Physics and Mathematics topics based on interdisciplinary, adaptability, interest and problem solving themes. The findings on impact revealed significant difference between the pre-test and post-test with a p-value  $< 0.0001$  and therefore the robotic activities had a significant impact on students' decision to choose a subject combination towards an Engineering career pathways. The study recommends that the government should facilitate the integration of educational robots in the current Science, Technology, Engineering and Mathematics curriculum through partnerships with research organizations such as universities and other research bodies to develop low cost and simple to use educational robotic kits. The study also recommends that through policy makers in education, the curriculum should be reviewed so as to adopt educational robots as a teaching/learning tool and teachers/instructors retrained on robotic use in education. Future studies should be conducted on the applicability of educational robotics in other subjects such as Biology, Geography, Chemistry, Agriculture and in Arts related subjects. The current study should be replicated in lower grades owing to the fact that the Kenyan curriculum is in transition from the traditional 8-4-4 system to the Competency Based Curriculum.

## TABLE OF CONTENTS

<b>DECLARATION.....</b>	<b>ii</b>
<b>DEDICATION.....</b>	<b>iii</b>
<b>ACKNOWLEDGMENT .....</b>	<b>iv</b>
<b>ABSTRACT .....</b>	<b>v</b>
<b>LIST OF TABLES .....</b>	<b>ix</b>
<b>LIST OF FIGURES .....</b>	<b>xi</b>
<b>ACRONYMS AND ABBREVIATIONS.....</b>	<b>xii</b>
<b>DEFINITION OF OPERATIONAL TERMS.....</b>	<b>xiii</b>
<b>CHAPTER ONE: INTRODUCTION .....</b>	<b>1</b>
1.1 Chapter Overview .....	1
1.2 Background of the study .....	1
1.3 Statement of the Problem .....	4
1.4 Objectives of the Study .....	6
1.4.1 General Objective .....	6
1.4.2 Specific Objectives .....	6
1.5 Research Questions and Hypotheses .....	6
1.6 Significance of the Study .....	7
1.7 Scope of the Research .....	8
1.8 Limitations of the Study .....	9
1.9 Delimitation of the Study .....	10
1.10 Assumptions of the Study.....	10
1.11 Contributions of the Study .....	11
1.12 Organization of the Thesis .....	11
<b>CHAPTER TWO: LITERATURE REVIEW.....</b>	<b>13</b>
2.1 Introduction .....	13
2.2 Educational robots for STEM Educational Purposes .....	13
2.3 Development of Robotic Activities based on educational Robots .....	17
2.4 Integration of Robotic Activities and its effect to the perception of STEM Subjects .....	20
2.5 The Impact of Robotic activities .....	23
2.6 Theoretical Framework .....	26
2.6.1 Constructivism Theory .....	26
2.6.2 Constructionism Theory .....	29

2.7 Conceptual Framework .....	32
2.8 Summary .....	33
<b>CHAPTER THREE: METHODOLOGY .....</b>	<b>36</b>
3.1 Introduction .....	36
3.2 Research Design .....	36
3.3 Study Variables .....	37
3.3.1 Independent Variable.....	37
3.3.2 Dependent Variables.....	38
3.4 Target population .....	38
3.5 Sampling Techniques and Sample Size .....	38
3.5.1 Sampling Techniques.....	38
3.5.2 Sample Size .....	39
3.5.3 Sampling procedure of the students.....	40
3.6 Data Collection Instruments.....	41
3.6.1 Questionnaires .....	42
3.6.2 Pre-tests and Post-tests .....	42
3.6.3 Interview Schedule .....	43
3.7 Validity of the instruments .....	43
3.8 Reliability of the instruments .....	44
3.9 Piloting of the Instruments .....	44
3.10 Data Collection Procedures .....	45
3.11 The Research Process.....	46
3.11.1 Fabrication of Educational Robotic Car and Arm .....	47
3.11.2 Selection of Hardware Components Used.....	47
3.11.3 Low-Cost Robot Fabrication Overview .....	49
3.11.4 Robotic Car.....	51
3.11.5 Robot Arm .....	62
3.11.6 Software adopted for the educational robots. ....	66
3.12 The procedure and implementation of the developed Robotic Activities.....	67
3.12.1 Development of the robotic activities.....	68
3.12.2 The implementation of the Robotics Activities.....	71
3.13 Integrated robotic activities in Physics and Mathematics education.....	78
3.14 Procedure of assessing the impact of the Robotic activities .....	79
3.15 Data Analysis Procedures.....	80
3.15.1 Analysis of Qualitative Data.....	80

3.15.2 Analysis of Quantitative Data.....	81
3.16 Ethical Issues.....	82
3.17 Summary .....	83
<b>CHAPTER 4: RESULTS AND DISCUSSION .....</b>	<b>84</b>
4.1 Introduction .....	84
4.2 Qualitative data findings .....	84
4.3 Fabrication of an Educational Robotic car and arm.....	85
4.3.1 Testing of the fabricated robots .....	85
4.3.2 Bill of Materials.....	88
4.3.3 Key informant Opinions over the Suitability of the Robots.....	90
4.4 Robotic Activities for integration to Physics and mathematics .....	94
4.4.1 Key informants’ opinions of the developed robotic activities.....	101
4.4.2 Key informants’ opinions of the integrated robotic activities .....	107
4.5 Quantitative data findings .....	112
4.5.1 Response Rate.....	112
4.5.2 Personal Information .....	113
4.6 The effect of Integration of Robotic Activities to perception of Physics and Mathematics .....	114
4.6.1 Pre-test findings on perception .....	115
4.6.2 Post-test findings on perception.....	117
4.7 Assessing the Impact of Robotic Activities on Students’ interest towards Engineering Career Pathways .....	120
4.7.1 Pre-test Findings on Impact or robotic activities.....	121
4.7.2 Post-test Results.....	128
4.8 The Impact of Robotic Activities to the Form 2 students .....	133
4.9 Summary .....	150
<b>CHAPTER FIVE: SUMMARY, CONCLUSION AND RECOMMENDATIONS.....</b>	<b>152</b>
5.1 Summary of Major Findings .....	152
5.2 Conclusion.....	155
5.3 Recommendations .....	156
5.3.1 Recommendations for Policy.....	155
5.3.2 Recommendation for Further Studies.....	155
<b>REFERENCES.....</b>	<b>158</b>
<b>APPENDICES .....</b>	<b>167</b>



## LIST OF TABLES

Table 3.1: Reliability Statistics .....	44
Table 3.2: Materials required for the Fabrication of the Robots.....	49
Table 3.3: Integration of Robotic Activities in Physics and Mathematics .....	78
Table 4.1: Estimated Cost of the Educational Robot.....	89
Table 4.2: Costs Comparisons for Robots used for Educational Purposes.....	89
Table 4.3: Developed Secondary School Robotic Activities.....	95
Table 4.4: Themes in Integration of Robotic Activities in Physics and Mathematics .....	96
Table 4.5: Themes in Integration of Robotic Activities in Physics and Mathematics .....	97
Table 4.6: Nature of Developed Robotic Activities.....	100
Table 4.7: Response Rate.....	113
Table 4.8: Personal Information of the Students .....	114
Table 4.9: Pretest Results Integration of Activities and Students' Perception of Physics and Mathematics .....	115
Table 4.10: Post-test Results Integration of Activities and Students' Perception of Physics and Mathematics .....	117
Table 4.11: Means on Pre-Robotic and Post-Robotic Integration of Activities .....	119
Table 4.12: Paired Sample t-test on Pre-Robotic and Post-Robotic Activities Integration .....	120
Table 4.13: Pretest Background on Physics and Mathematics .....	121
Table 4.14: Pretest Background on Robots.....	123
Table 4.15: Pretest Findings on Impact of Integration of Activities.....	124
Table 4.16: Pretest Findings on Career Interest.....	126
Table 4.17: Posttest Background on Physics and Mathematics.....	128
Table 4.18: Post-test Background on Robots.....	129
Table 4.19: Posttest Findings on Impact of integration of Robotic Activities.....	130
Table 4.20: Posttest Career Interest .....	131
Table 4.21: Sign Test on Background on Physics and Mathematics .....	135
Table 4.22: Pre-Impact and Post-Test Impact Means .....	136
Table 4.23: Correlation between Pre-Impact and Post-Impact .....	136
Table 4.24: Paired Sample t-test on Impact .....	137
Table 4.25: Pre-Career Interest and Post-Career Interest Means.....	138
Table 4.26: Correlation between Pre-Career and Post-Career Interest.....	138
Table 4. 27: Paired Sample t-test on Pre-Career and Post-Career Interest .....	138
Table 4.28: Mean Exam Score .....	140
Table 4.29: One-Way ANOVA of Difference in Exam Scores .....	140
Table 4.30: Multiple Comparisons of Mean Exam Scores among Experimental Groups .....	141
Table 4.31: Mean Exam Score across Gender .....	141
Table 4.32: Independent Samples t-test for difference in Means .....	143
Table 4.33: Descriptive Statistics of Exam Scores across School Categories .....	144
Table 4.34: ANOVA Analysis of Difference in Exam Scores across School Categories.....	145

Table 4.35: Multiple Pairwise Comparison Test for Differences in Exam Scores among School Categories.....	146
Table 4.36: Cross-Tabulation Results on Actual versus Expected Physics Selection .....	147
Table 4.37: Chi-Square Test on Actual and Expected Physics Selection.....	148

## LIST OF FIGURES

Figure 2.1: Conceptual Framework .....	32
Figure 3.1: Research Process .....	47
Figure 3.2: Direct Current Motor and Robot Wheel.....	52
Figure 3.3: Infrared Sensor .....	54
Figure 3.4: Ultrasonic Sensor.....	55
Figure 3.5: Robot Black Pathways.....	55
Figure 3.6: Line Follower Wiring Diagram .....	56
Figure 3.7: Flow Chart for the Line Following Robot.....	57
Figure 3.8: Wiring Diagram for an Obstacle Sensor Robot.....	58
Figure 3.9: Flow Chart for the Obstacle Avoidance Robot .....	59
Figure 3.10: Arduino Microcontroller .....	61
Figure 3.11: Raspberry Pi .....	61
Figure 3.12: Block Diagram of the Robotic Car .....	62
Figure 3.13: Servomotor .....	64
Figure 3.14: Wiring Diagram for Robot Arm .....	65
Figure 3.15: Block Diagram for the Robotic Arm Design.....	65
Figure 3.16: Flow Chart for the Robotic Arm Operation .....	66
Figure 3.17: Block Diagram on Development of Educational Robotic Activities ....	68
Figure 3.18: Steps in Developing Educational Robotic Activities .....	70
Figure 3.19: Blockchain Diagram on Integration of the Educational Robotic Activities .....	76
Figure 4.1: Robotic Car Design .....	87
Figure 4.2: Robotic Arm Design.....	88
Figure 4.3: Student Undertaking Line Following Activity .....	98
Figure 4.4: Students Undertaking Robotic Arm Activity .....	98
Figure 4.5: Technical Drawing Activities.....	99
Figure 4.6: Students doing Solar Energy Activities.....	99
Figure 4.7: Participants according to the School Categories .....	113
Figure 4.8: Gender of the Participants .....	114
Figure 4.9: Responses on Prior Interaction with a Robot .....	122
Figure 4.10: Class when Participant Started thinking about Career Pathways.....	127
Figure 4.11: Learners' Perception of how Robotic Activities Improved Understanding of the Subjects .....	133
Figure 4.12: Line Plot of the Exam Scores .....	139

## **ACRONYMS AND ABBREVIATIONS**

<b>ANOVA</b>	Analysis of Variance
<b>CBC</b>	Competency-based Curriculum
<b>CEMASTEА</b>	Centre for Mathematics, Science and Technology Education in Africa
<b>DC</b>	Direct Current
<b>GND</b>	Ground
<b>IC</b>	Integrated Circuit
<b>ICT</b>	Information and Communication Technology
<b>ISTE</b>	International Society for Technology in Education
<b>MRR</b>	Mixed Method Research
<b>NACOSTI</b>	National Commission for Science, Technology and innovation
<b>RX</b>	Receiver
<b>SCECPQ</b>	Student Choice of Engineering Career Pathways Questionnaire
<b>SIECQ</b>	Student Interests towards Engineering Career Questionnaire
<b>SPSS</b>	Statistical package for Social Scientists
<b>STEM</b>	Science, Technology, Engineering and Mathematics
<b>TX</b>	Transmitter
<b>USB</b>	Universal Serial Bus
<b>VCC</b>	Common Collector Voltage
<b>RAAS</b>	Robotics Activities Attitudes Scale

## DEFINITION OF OPERATIONAL TERMS

**Educational Robotics:** These are robots designed to support the teaching and learning process of sciences by providing an interdisciplinary environment.

**Engineering career pathways:** This refers to a career route taken by a learner in order to attain an Engineering career goal or goals.

**Form 2 students:** This is the second level of the possible four levels in secondary school education in Kenya

**Hardware:** These are the physical components of a microcontroller or of a robot

**Impact:** This refers to a notable effect after the use of educational robots in teaching and learning of STEM subjects.

**Integration:** This is the act of combining robotic activities to the existing Physics and Mathematics contents

**Precollege exposure:** This is an educational experience that prepares secondary school students for the transition to a college environment.

**Programme:** It is a set of instruction used to perform a certain task.

**Robot:** This is a programmable device used to perform some specific tasks.

**Sensor:** It is a device used to detect a physical property and produces a signal that can be interpreted by a microcontroller

**Software:** It is a set of instructions, data or programs used to operate a robot.

**STEM:** It is an abbreviation associated with four areas of study including science, technology, Engineering and Mathematics.

## **CHAPTER ONE**

### **INTRODUCTION**

#### **1.1 Chapter Overview**

This chapter outlines the background information, the statement of the problem and the objectives of the study, the research questions and hypothesis. In addition, the chapter provides the significance of the study, the scope of the research, the delimitations, the limitations and the assumptions of the study.

#### **1.2 Background of the study**

Secondary schools play a pivotal role in preparation of learners towards choosing a career. When learners are enrolled to secondary school level of education, they are exposed to variety of subjects from which they can select subject combinations based on their interest and their preferred future career pathways. This selection process is very important and is characterized by challenges especially where learners are not properly guided. (Njeru, 2016; Kazi & Akhlaq, 2017).

Science, Technology, Engineering and Mathematics careers are key in providing manpower to a growing economy thereby enhancing innovation and greater productivity (DeCoito, 2016). This therefore calls for creative ways of teaching the STEM subjects in order to encourage more students to pursue such careers. This can be supported by enhancing that students go through the preparation process towards the STEM careers which can be done by adopting new teaching and learning perspectives to enhance the learning experiences and interest in the STEM career (Carnevale, Smith & Melton, 2011). Research in STEM fields has grown, with the priority of many researchers being contribution to the growth of the field, improvement in the STEM workforce and to maintain more students in these fields.

Furthermore, the students are trained in the STEM field in a way that they can compete in the global market (Bybee 2010; Heilbronner, 2011). According to Sadler *et al.*, (2012) students are prepared for the STEM related career long before they join post-secondary levels of education. This agrees with the findings of Malin, Bragg and Hackmann (2017), who indicated that secondary school education prepares the learners for the future career. The preparation process is complex, in that technology advances rapidly and therefore there is need to advance teaching strategies to match the advancing technology (Hajkowicz *et al.*, 2016).

The education system in any nation should always ensure that the secondary schools prepare students to meet the inevitable demands of a STEM workforce by motivating more learners toward Science, Technology, Engineering and Mathematics (STEM). The schools have a great role in preparing future workforce (International Society for Technology in Education, ISTE, 2017). International Society for Technology in Education focuses on standards development for purposes of ensuring that students acquire the requisite skills in preparation of the future. The developed standards help in fostering of students learning, digital competence, construction of knowledge, innovation, computational thinking, creative communicators, and global collaborators (ISTE, 2017).

One of the ways of improving numbers in STEM is by introducing Engineering to the pre-college levels. This can be achieved by introduction and increase of formal and informal pre-college Engineering programmes (Phelps, Camburn & Min, 2018). The foundation of such pre-college programmes is hinged on the premise that prior exposure of students to Engineering will encourage them to pursue college careers in

Engineering and strengthen their pursuit for such careers (Fantz, Siller, & Demiranda, 2011).

According to Salzman and Ohland (2015), the introduction of pre-college Engineering activities to the secondary school students has a great impact to those who join university Engineering studies. Some of the benefits drawn from such activities include knowledge of Engineering design, growth in technical understanding and skills. The skills include development of teamwork spirit and improvement in communicating technical ideas. The pre-college Engineering programmes also expose learners to real life learning environment and prepare them on what to expect in the Engineering career (Acut, 2021).

According to Anwar *et al.*, (2019) robotic activities form part of the activities that can be employed in pre-college programmes and for prior exposure to Engineering. Eguchi (2014) noted that the activities engage the learners actively thereby exposing them to the practical part of the STEM disciplines thereby improving knowledge and skills application in these disciplines. Additionally, Altin and Pedaste (2013) noted that including robotics in school subjects is beneficial to students in a countless way. Some of the benefits derived from the exposure include advancement and use of STEM knowledge, computational thinking, skills for problem-solving, enhancing creativity, persistence, social interactions, and teamwork skills.

According to Gura (2012) educational robotics are key scientific and Engineering practices in that they help students to improve skills that are difficult to learn through the traditional learning methods. In contrast to these traditional technologies and



methods of teaching, students exhibit improved interest and performance when exposed to educational robotics in the STEM related subjects (Chin *et al.*, 2014).

Researchers have also agreed that robots can be designed and implemented with the main aim of enhancing teaching and learning. Several designs and kits have been developed and proposed for teaching purposes and have greatly contributed to the education field. LEGO Mindstorms kits are such designs and are considered to be among the most popular tools for teaching general robotics and programming (Fitriyaningsih *et al.*, 2019). The MiniSkybot is another design that can be used for educational purposes. The design enables students to create new parts according to their innovativeness (García-Saura *et al.*, 2012). The designs have been developed but the criterion of developing the robotic activities from the designs have not been investigated. Furthermore, the role of the activities in formal learning of STEM subjects and their ultimate impact on career choice have not been investigated. In this research educational robots were designed and activities related to them developed.

The impact of the integrated activities to the STEM subjects to the secondary school students on choice of career was then examined. Understanding the impact of these activities would help guide education stake holders in providing the best environment and exposure to secondary school students which may in turn create some interest and influence the choice of Engineering career.

### **1.3 Statement of the Problem**

There has been a growing demand in developing countries for STEM related work force, with knowledge and technological skills to promote industrialization and economic growth (Kelley *et al.*, 2020). Despite the growing demand, students' interest towards STEM related careers has been on a downward trend in many nations

(Thomas & Watters, 2015). Thus, it is important to have learners engaged and inspired in STEM related activities to promote the interest the STEM careers.

Engineering is part of the STEM fields, and as such exposing students to it early enough can play a great role in preparing the students to the Engineering career (Mohd Shahali *et al.*, 2019). This positions secondary schools in Kenya as key players in preparing students for career choice. Therefore, exposure to Engineering related activities can be very beneficial to secondary school students.

One of the ways of exposing learners to Engineering is through educational robots and robotic activities. Currently, there are a good number of robotic kits available for educational purposes, with the most popular ones being LEGO Mindstorms and WEDO Kits. These designs are expensive with most of the available robotic kits costing slightly above 450 US dollars. Therefore, most of the government-owned secondary schools, especially in developing countries, may not be able to acquire them (Wilson & Okraku-Yirenkyi, 2019). It would therefore, be prudent to develop low-cost educational robots and suitable robotic activities which can be customized to meet Kenyan curriculum needs.

Further, most of the researchers do not follow up, after exposing the students to robotic activities to assess the impact of the educational robots. For instance, no follow-up has been made locally to find out whether the exposure to the readily available educational robots will lead to students choosing STEM related subjects in secondary schools. A follow-up after exposure is therefore necessary to assess whether the educational robots would motivate students towards choosing Engineering related subjects. Also evident is the fact that little research has been done to establish the influence of

Engineering exposure to Secondary School students through robotic activities in improving their interest towards an Engineering career pathways in Kenya. The available studies have focused on impact of educational robots on higher education; most notable being Mwaringa (2017).

Based on this, the current study was conducted to develop low cost educational robots, develop suitable robotic activities, integrate the activities into Physics and Mathematics and evaluate the effects of the integration and finally assess the impact of the activities in the choice of an Engineering career pathways.

## **1.4 Objectives of the Study**

### **1.4.1 General Objective**

The main objective of this study was to investigate the impact of educational robotic activities on secondary school students' interest in Engineering career pathways.

### **1.4.2 Specific Objectives**

The specific objectives of this study were to:

- i) Fabricate and assemble a low cost robotic car and arm for secondary school students' STEM educational purposes.
- ii) Develop suitable secondary school robotic activities based on the fabricated robots for integration in Physics and Mathematics.
- iii) Examine the effect of exposing the learners to the integrated developed robotic activities on their perception of Physics and Mathematics.
- iv) Assess the impact of the robotic activities integrated to Physics and Mathematics to students' interest in Engineering career pathways.

## **1.5 Research Questions and Hypotheses**

The study sought to answer the following research questions:

- i) What robot designs are suitable and affordable for STEM educational purposes?
- ii) Which suitable secondary school robotic activities can be developed based on the fabricated educational robot for integration purposes?
- iii) H<sub>01</sub>: The integrated developed robotic activities do not have a significant effect on students' perception of Physics and Mathematics.
- iv) H<sub>02</sub>: The robotic activities do not have a significant impact on students' interest in Engineering career pathways.

### **1.6 Significance of the Study**

This study investigated the impact of prior exposure of form 2 students to Engineering through robotic activities to the interest in the Engineering career choice. The study has contributed to the existing knowledge in the area of use of technology in education by highlighting the impact of educational robotics. The findings from this study may be implemented by education stakeholders in order to improve teaching and learning of theory and practice in STEM related subjects. The findings revealed the effect of the use of educational robotics in promoting interest in STEM related careers. This therefore adds to the scholarly information in educational technology which could be used to expand knowledge scope and reference for future studies. Additionally, the findings could also guide curriculum developers and implementers, and other policy makers especially in the Ministry of Education on how to make STEM subjects more attractive to learners thereby promoting growth in STEM related careers. The education policy makers can also employ the findings in this study to formulate strategies that would enhance incorporation of technology in education. Furthermore, the findings could support the development of Competency Based Curriculum related

activities and integration of the activities for the Junior secondary in preparation to STEM oriented careers in senior secondary school level.

The current study aligns with two pillars of Vision 2030; social and economic pillars where science, technology and innovation are the main foundations. The recognition of science, technology and innovation in these pillars has the likelihood of boosting creation of wealth, social welfare and competition that surpasses Kenya's boundaries. The multi-stakeholder Nation Strategy in ICT for Education and Training implemented in 2006 laid the required prerequisites for a human resource that is skilled, towards achieving Vision 2030. Integration of technology stretches the restrictions of the classroom to enhance creativity and innovation which would help in development of a skilled human resource as per Vision 2030.

### **1.7 Scope of the Research**

This research focused on fabricating of a low cost robotic car and arm, the effect that the robotics activities had on students' perception of Physics and Mathematics. It further assessed the impact the exposure to the robotic activities had on the interest of the students to Engineering career pathways. Though there are several aspects regarding how beneficial educational robots are, the focus of the study was only on the impact of educational robots on students' interest towards an Engineering oriented career. The theoretical scope for the study included constructivism and constructionism theories. The study was conducted on public secondary schools in Kangema Sub-County. The sample size for the study was 270 Form Two students. The geographical scope for the study was Kangema Sub-County, Murang'a County. Only students from public secondary schools were included in the study. Physics and Mathematics teachers from the schools where students were selected, were also

included in the study as key informants. The study was conducted from June 2021 to December 2021 and a follow up done on June 2022.

### **1.8 Limitations of the Study**

This research focused on the impact of educational robotics and the activities thereof to Form 2 secondary school students' interest in Engineering career pathways. There is inadequate literature on the impact of educational robotics in Kenya. As a result of this the researcher widened his search to other regions beyond Africa. The students were likely to give their responses and make decisions based on excitement during the exposure. This was mitigated by a post experiment follow up which was carried out at the end of form 2 in order to rule out such a possibility and ascertain the actual position.

Exposing the learners to educational robotic kits would be expensive due to the high numbers of students sampled and due to the scattered locations of the schools. This was mitigated by introducing a low cost robotic kit designed from locally available and recycled materials. Additionally, the learners were brought to Murang'a University in smaller groups which made it easier to conduct the study.

There was a possibility of students with prior exposure to these activities and other forms of Technology losing interest in the current activities. To mitigate this, the researcher designed a kit that was unique and developed activities that would aid in formal learning as compared to most of the other studies that were informal. Another limitation that faced the study was a possibility of learners fearing to respond confidently as a result of fear, majorly in examinations. In order to mitigate this, the researcher assured the students of confidentiality and that the collected data would only be utilized for purposes of the current study.

### **1.9 Delimitation of the Study**

1. This study was delimited to form 2 students in public schools in Kangema Sub-County, Murang'a County. It did not include students in other forms. The impact of the integration of the robotic activities to the form 2 student was measured using Student Interests towards Engineering Career Questionnaire
2. The study also delimited itself to Physics and Mathematics teachers from Public Secondary Schools
3. The study was delimited to design of educational robot, development of robotic activities using robot designs, integration of the activities to Physics and Mathematics and the impact of the activities to Engineering career choice
4. Only the questions approved after the pilot study were included in the final research instruments used in data collection.

### **1.10 Assumptions of the Study**

The study was based on the following assumptions;

- i. The fabricated robotic car and arm would be suitable for development of activities Secondary School students' exposure to Engineering.
- ii. All participants in the study would be receptive to provide the required responses.
- iii. The developed activities would be easily integrated to the selected topics in Physics and Mathematics.
- iv. The observed changes in interest towards an Engineering career pathways were as a result of exposure to the educational robotic activities.

### **1.11 Contributions of the Study**

From this study low cost robotic car and arm were fabricated. The robots were affordable and suitable for use as teaching aids in the STEM related subjects. Secondly, robotics activities were developed and integrated to Physics and Mathematics topics. The robotic activities developed were suitable for use in teaching the said subjects. The themes developed in this study in the process of integration can further be used for similar development of activities. The study further contributes to the understanding that there are activities that would improve the learners' perception of Physics and Mathematics. The study established that the use of robotic activities in teaching and learning of Mathematics improve the learners interest in engineering career pathways. Finally, three papers containing the results of this has been published.

### **1.12 Organization of the Thesis**

This thesis is organized into Five chapters as summarized below.

Chapter One, highlights the background of the study, the problem statement, Objectives of the study, the research questions, the significance of the study, the scope of the study, the limitations and delimitations of the study, Theoretical framework, Conceptual framework, the Assumptions and the Contributions of the study.

In Chapter Two, Literature review is presented. The related works done previously on educational robotics are discussed. This includes the robots designed and employed for educational purposes and their effects to education.

Chapter Three discusses the research methodology employed in the research. It covers the methodology followed in order to achieve the research objectives. This includes the research design, the sampling procedure, Data collection tools, Validity and



reliability of the data collection tools, Data collection procedures, the research process, Data analysis procedure and the ethical issues.

Chapter Four presents and discusses the results of the study findings. In chapter, the results are analyzed per objectives of this study. The suitability of the fabricated robots and the developed robotic activities are discussed, Additionally, the impact of the exposure to the integrated activities is discussed.

Chapter Five covers the summary of major findings, the conclusion made from the study, the recommendations by the researcher.

## **CHAPTER TWO**

### **LITERATURE REVIEW**

#### **2.1 Introduction**

This chapter reviews studies on educational robots and robotic activities in STEM education. Literature in the areas of design and fabrication of educational robotics in secondary schools was analyzed in details. The chapter also analyses the aspect of development of robotic activities for integration in STEM subjects. It also outlines the integration of robotic activities and the impact of such integration.

#### **2.2 Educational robots for STEM Educational Purposes**

Numerous educational robots in different models and functions exist in the market today (Tsoy *et al.*, 2018). The educational robots use different programming tools which aid in the study of mechanical parts of the robots and programming of the robot at the same time. However, according to Bagnall (2014) the most popular robotic kits are those with LEGO Mindstorms EV3 mostly utilized in studying basics of robotics by students in pre-college levels as well as by students in college levels. However, other designs have been known to exist in different STEM disciplines, for instance WEDO kits (Veselovská & Mayerová, 2017), Makeblock (Feijoo-Almonacid & Rodriguez-Garavito, 2022) and Cubelets robotic kits (Correll, Wailes & Slaby, 2014). For instance, Vandeveldel *et al.*, (2016) built a robot from scratch for use in education.

While the project borrowed a lot of design from numerous robots that existed, the aim was to simplify the software and electronics aspects of the robots used in education. The motive in this case was to come up with a low-cost robot that students could assemble by themselves. The study adopted three distinct systems of construction- laser-cut screw connectors, printed friction-fit connectors and a hybrid system- all

adopting T-slot extrusions of small aluminum. The project involved 86 pre-college students and 35 teachers where these robots were tested. Through the use of questionnaires and evaluation experts, all the three robots were tested for their usability and functionality in 5 days. On overall, all the participants gave preference on the hybrid robot since it was quick to construct and was firm once assembled for it relied on interlocking shapes and screw connections. However, the study could not ascertain on whether the work presented a construction system that was inexpensive or not, thus presenting a major weakness of the entire study.

Chomyim, Chaisanit and Trangansri (2015) designed mobile robot kits for use in education and research. The design of the robots in this case aimed at creating modular systems, while at the same time considering materials required in assembly in addition to a variety of user activities. In their designing of the robotic kits, the project utilized locally available materials, thus optimizing the cost of the kits. Further, creation of the modular systems helped students in integrating the kits to various disciplines quickly and easily while at the same time eradicating the requirement for tasks that were unsafe such as soldering. As a result, the robotic kits designed would enhance creativity in the learners thus improving education in different disciplines.

On the other hand, Kim *et al.*, (2019) undertook a study where a RoboSTEM was developed whose aim was to help teachers in designing and implementing STEM lessons using educational robots. In the design of the RoboSTEM, the authors acknowledged that the programming used should be based on theoretical foundations that can be easily understood and that the design should be easy to describe to the users, especially teachers. Further, the study hailed the success of the RoboSTEM in teaching from the usability surveys conducted aiding in designs improvements.

However, the RoboSTEM was limited to the fact that it did not involve the students who were the end users of the educational robots, a limitation that the current study seeks to address by incorporating students in the entire experiment.

Yamanoor and Yamanoor (2017) developed the Raspberry Pi software for use in educational robots. The aim was to enhance high quality robots at low cost. The study involved robots running on 3 different Raspberry Pi variants: Models A, B and Zero. Based on the robots developed, the robots running on the Raspberry Pi Zero variant were easy to design since the software involved codes that could be easily manipulated for different tasks of learning. Thus, Yamanoor and Yamanoor (2017) suggestion was that robots should be developed using easily available and easy to manipulate software for optimal outcomes in education. The study suggested the creation of robots based on hybrid software that would incorporate the Raspberry Pi Zero and the open access software such as Arduino. The current study borrowed on the use of open access software that was readily available, by using Arduino in the assembly and fabrication of the educational robots.

Ardublock robot was designed and incorporated in teaching of STEM subjects in Greece by Xenakis and Brentas (2019). In order to evaluate the performance of the robot designed, an experiment was performed which involved comparing the performance of the Ardublock robot built by use of recycled materials with robots developed by robot manufacturing companies bought from approved shops in Greece. The design of the Ardublock robots was unique in that it involved learners in making Ardublock programs and in the assembling of the robots from recycled materials. The study involved two sets of students, team A using robots bought from approved shops which were running on commercial-based materials running on LEGO programs and

team B using the Ardublock design. Questions assessing self-efficacy for computational thinking were then given to the two sets of students. Using paired sample t-tests, a significant difference was observed with team B scoring higher scores. Therefore, use of open software and locally available recyclable materials while in the same time involving the end users understand the functionality of educational robots, such as the Ardublock robot, improved the efficiency of educational robots.

On the other hand, HYDRA robot was developed by Tsalmpouris *et al.*, (2021) for STEM education in Greece. The aim was to introduce a low-cost robot running on Arduino microcontroller. The robot HYDRA differed from the existing robots in the markets due to their system that was modular in nature and expandable. Additionally, the complexity of the microprocessor was reduced so as to suit students with no prior knowledge in programming and subjects related to design of robots. Based on the study's findings, it was evident that robots based on less complex modified Arduino software made it possible for students, in the last grades of elementary learning, to grasp concepts in STEM in a short time span and made it possible for them to perform tasks that were straightforward and appealing, thus boosting their self-esteem and creativity.

In Chile and Colombia, Cano (2022) developed educational robots for teaching STEM subjects. The robots designed utilized Arduino and had a gender approach, taking into consideration different needs by women. The study involved a mixed research methodology, where qualitative and quantitative data was collected from teachers and students. Evident from the findings was that design of educational robots should incorporate components such as Arduino and readily available materials that have a

real-life connection, which would be a motivation for use by the end-users especially the students. From the workshops carried out on the students, it was evident that students would relate with the tasks carried out by the robots and easily understood the functionality of the robots, which further increased their creativity, motivation and attitude.

### **2.3 Development of Robotic Activities based on educational Robots**

Angel-Fernandez and Vincze (2018) defined educational robotics as a field of study whose main goal is to improve learning experiences of learners by the developing and implementing activities related to robots. Development of educational robotic activities therefore involves activities that enhance familiarization on the use and functionality of physical robots (Screpanti *et al.*, 2018). There are a few examples of educational robots like LEGO Mindstorms among other robots designed purposely to support the robotic activities.

The robotic activities can be developed for learners at different levels for instance from elementary to graduate levels. These may include design, programming, application, or experimentation with robots. Educational robotics activities usually consist of the use of a robotics kit, with which learners learn how to build and programme robots for a given task (Jung & Won, 2018). The activities can take the form of interventions, after-school activities, voluntary classes, or a whole course based on robotics (Screpanti *et al.*, 2018).

According to Danahy *et al.*, (2014), the basis for the application of educational robots is broad, but the constructionist educational approach has been the most outstanding. Robotics kits provide a modular approach regarding programming and building, often

used as creativity-enhancing interventions in the school context. In working with these kits, students can exert Engineering competencies and creative solutions to a vast array of problems, starting from making a robot move between two points.

In the sailboat robots' implementation by Chen and Chang (2018), development of robotic activities followed a task-centered model which involved dividing the entire project into tasks that would help in familiarizing the users with the sailboat robot. Each task required different skills and concepts. Specifically, the development of robotic activities in this case required the participants to construct a sail car, then a hull, understand basic programming concepts in Arduino, link the sail car with Arduino and assemble it into a functional sailboat, engage in some sailboat robotics on their own and finally engage in some assessments that they felt the sailboat would accomplish (what was referred to as sailboat robotics). Through these tasks, the participants understood the components and functioning of the sailboat prior to integrating select STEM topics.

A study involving students in K12 comprising of 12 girls and 8 boys was carried out by Scaradozzi *et al.*, (2020) where they developed activities on educational robotics for use in STEM education. Through constructionism pedagogical approach that emphasizes on the need for learners to create and experiment, an approach that was learner-centered was applied in developing the robotic activities. This involved problem-based learning where learners were taken through the robotics' fundamental aspects and then presented with challenges that they were required to solve. This led to students performing robotic activities based on Think, Make, Improve (TMI) model. Students figured out how a challenge would look like (thinking), then tried to

achieve a solution by manipulating the robot (Make) and lastly watched keenly their newly created robots where they tried to improve them for efficiency and accuracy.

A study that was conducted by Ziaeeefard *et al.*, (2017) aimed at studying the effect of learning contexts that were meaningful and activities that were hands-on in broadening participation and ensuring that pre-college students in USA sustained studying STEM subjects in their entire study period. The study designed two robots that would work with learners (co-robots). While developing the robotic activities, the study evaluated whether they aligned with factors related to Robotics Activities Attitudes Scale (RAAS) as outlined in Cross *et al.*, (2016) which included value of real-life experiences, motivation, interest and confidence. From the assessment results, the students indicated that the activities were fun and that they enjoyed the activities which were hands-on in learning STEM related concepts. A comparison of the pre and post exposure responses revealed that students perceived activities related to STEM as more interesting when executing them using the co-robots. Further, students exceeding 50 percent found activities in assembling the robots and modifying them as exciting. However, the study was cross-disciplinary thus involving a wide range of STEM related concepts which may have an effect on the time that the learners were exposed to the co-robots and different activities. This may have affected responses based on RAAS; a shortcoming that this study seeks to address by only engaging students with activities on two STEM subjects thus giving them sufficient time to interact with the educational robot.



## **2.4 Integration of Robotic Activities and its effect to the perception of STEM**

### **Subjects**

Integration of developed robotic activities involves integrating concepts in different disciplines and expected learning outcomes into a theme. Chen and Chang (2018) conducted a study on integrated robotics STEM course. The study adopted the use of a sailboat robot theme. Prior to integrating the developed activities in STEM, the authors developed a web approach. The sailboat theme was chosen for the study since it was interdisciplinary requiring Physics, Mathematics and Engineering concepts. Specifically, the sailboat robotic activities were integrated in teaching motion and force in Physics, trigonometry and functions in Mathematics and illustration and optimization in Engineering.

Integration of sailboat robot as outlined in Chen and Chang (2018) involved 7 units. Under Unit 1, there was introduction on forces where different aspects such as frictional resistance, relationship between force and surface area were taught with students required to perform simulations, thus enhancing their understanding on manipulating sailboat movement. In Unit 2, geometry and buoyancy were instructed. Unit 3 involved understanding the programming aspects so as to manipulate the sailboat into performing different academic tasks while Unit 4 involved instructions on input/output analysis in electronics. Unit 5 was basics on repairs and maintenance of the sailboat robot, where students were even allowed to tailor-make the robot and if possible launch their own-make. In Units 6 and 7, important Engineering concepts were introduced such as optimization, where optimal decisions were to be made such as cost decisions, stability among others.

A study by Benitti and Spolaor (2017) involved a systematic review of 60 publications to evaluate concepts considered in educational robots and how the robots are integrated in the school curriculum. From the literature reviewed, it was noted that flexible robots are the best in developing activities for integration purposes across various disciplines in the education curriculum. For Ching *et al.*, (2019), integration of robotics in elementary schools' curriculum should adopt a project-based learning (PBL) approach. The PBL approach enables the structuring of the overall curriculum by giving the students opportunities to investigate authentic topics or problems. In addition, students can engage in learning STEM related topics through active creation of artifacts with teachers acting as facilitators during the hands-on activities.

In the United States of America, Ntemngwa and Oliver (2018) conducted a study on how robots would be integrated in STEM instructions. The study was conducted using learners and teachers in Middle Level of education. LEGO Mindstorms EV3 based robots were used in the study. During integration of different robotic activities in STEM subjects, the study found it necessary to restructure the STEM curriculum in themes so as to align it within the project of the robotics. For instance, in this case, different themes were created such as the "Body Forward" to integrate anything that was related to the body systems of animals, "asteroid exploration theme" for teaching topics related to astronomy and scientific exploration of planets, "the color sorting project" whose aim was to teach topics related to optics, "acceleration theme" for Linear Motion amongst others. This way, teachers would simply fit simple instructions into an existing theme thus making it easier to implement educational robots in learning.

According to Scaradozzi *et al.*, (2015) educational robotics provides an innovative approach of teaching. The approach suggested was tested using learners in a select Italian primary school. The study involved robots that ran on LEGO WeDo and LEGO Mindstorms NXT hardware and software. The robots were integrated in teaching Science and Mathematics topics. The study found that robotics should be integrated in teaching Science and Mathematics in line with the school curriculum so as to witness an upgrade in learning of the subjects. While integrating the robotic activities in Science and Mathematics, the aim should be to expose learners to hands-on opportunities that engage them in applying the knowledge and skills they have learned across disciplines.

There has been growing interest of educational communities in robotics as indicated by Benitti, (2012). Robotics activities help create a fun and engaging hands-on learning environment for learners (Eguchi, 2014; Mataric *et al.*, 2007). Khanlari (2013) conducted a qualitative study with experienced robotics teachers where he wanted to establish whether robotics could have effect in teaching STEM subjects. The study concluded that robotics and related activities help learners understand STEM subjects and enhances learners' interest in STEM fields. Nugent *et al.* (2016) conducted research where they collected data from 2409 campers, competition, and club participants during six years. The study revealed that robotics activities increased participants' awareness of STEM content perceived and problem-solving skills. Similarly, Conrad *et al.* (2018)

In Canada, Khanlari and Mansourkiaie (2015) evaluated the perceptions of teachers on using educational robots in STEM education. One of the research questions in the study involved teachers providing sample topics in Primary and elementary STEM

subjects that would be easily taught using robotics. This was after the participants were exposed to functional robots that used hardware and software of LEGO MINDSTORM. From the findings, it was evident that the teachers indicated that robots can be used in teaching some Mathematics topics such as geometry, multiplication, addition, subtraction, division, measurement, shapes, orientation and movement of bodies. Teachers also stated that science topics such as circuits, force, motion, force, matter and structures could be taught using robots.

## **2.5 The Impact of Robotic activities**

The impact of robotic activities depends on the level of the learner as noted in a study by Doerschuk *et al.*, (2016). The study claims that hands-on learning using educational robots improve the interest of students and career advancement towards STEM oriented learning. Eguchi (2016) verifies this claim by opining that educational robots present an opportunity for learners to practice and gain real-life experience that is goal-oriented, thus having a long term impact on the future of learners learning in fields related to STEM. However, there are specific studies that have focused on creating educational robots and implementing their functionality on learners and further assessing their effect or impact on learners' career pathways decision.

For instance, Tiryaki and Adguzel (2021) developed a robot for STEM learning that ran on an Arduino interface. The impact of the robotic application was tested on 30 7<sup>th</sup> grade learners in a select school in Istanbul, Turkey with another 30 7<sup>th</sup> grade learners acting as a control group. Through a questionnaire, containing Test of Science Related Attitude (TOSRA) items, data was collected. From the results, it was evident that robotics applications in STEM increased the creativity and attitude of learners towards STEM significantly. The study also unearthed that use of educational robots in STEM

helped students have a glimpse of real-life and daily life STEM-based problems which made them feel like scientists in the course of the practices which in turn affected their career choices in the future.

In Taiwan, Chen and Chang (2018) developed a sailboat running on an Arduino program and tested its effectiveness on improving the career choice of learners in Grade 10. The study involved 42 learners in the experimental group. Additionally, the study also involved a control group comprising of 40 grade 10 learners who used a robot running on LEGO Mindstorm bought from local approved shops. Through paired t-tests, the difference between the two robots on interest of learners on STEM courses and their career orientation towards STEM courses was assessed. From the results, the experimental group posted higher means in interest and career orientation, which were significantly different from the control group. This implied that the sailboat when integrated in STEM curriculum enhanced the interest of learners in STEM related subjects and career orientation towards STEM related courses to a level that was higher as compared to the robot that was assembled elsewhere.

Goh and Ali (2014) experimented on the impact of educational robots on students' career choices in Malaysia. The study employed a robot that was programmable and could be reconfigured using LEGO NXT Mindstorm. The study's sample was 44 years 10 students (Form 4 Learners). Data was collected using a questionnaire containing items on STEM Career Interest Scale. Distribution of the questionnaires was pre and post survey after which analysis was done. Overall paired analysis of the STEM Career Interest Scale responses showed differences that were significant in favor of the higher posttest mean. Thus, the study inferred that, after exposure to the educational robot,

students developed an increase in beliefs and interests in relation to STEM related learning which led to aspirations that were positive towards STEM related careers.

Hammack *et al.*, (2015) investigated on the effect of an Engineering Camp on Students' Perceptions of Engineering and Technology. Their research showed that students tend to have inaccurate views of who engineers are and what they do. This would hamper the choice of Engineering as a career. The study intended to measure the effect of participating in a week long Engineering summer camp to middle level students. The researchers concluded that participation in such a camp resulted to a positive impact on the perception and understanding all about what technology is and the work done by engineers, thus improving their career orientation towards Engineering.

Afari and Khine, (2017) while conducting a study on the impact of robots in the United Arab Emirates distributed LEGO Mindstorms to pre-college learners. The study noted that technology plays an important role in development of skills. They also noted that robotics expose learners to opportunities and challenges helping the learners to become innovative in ideas and in critical thinking. The result outlined how robotics can be effectively used as an educational tool and the impact it has on students' interests in STEM related subjects.

Two studies were conducted in Italy by D'Amico, Guastella and Chella (2020) to evaluate the impact of robots in teaching Physics and Geography. The studies engaged two groups, an upper and a lower secondary school groups. In each group the sample was divided into an experimental group and a control group. The participants were subjected to an assessment before and after the exposure to LEGO Mindstorm EV3

robots. From the ANOVA results, students involved in the experiment had significantly higher results in Physics and Geography as compared to the control group. The results also showed that the interest of the experimental group towards Physics and Geography increased significantly as compared to the control groups.

Rocker Yoel *et al.*, (2020) implemented the FIRST robots in Israel and assessed whether they had an impact on FIRST participants' decision to undertake STEM related courses in the University and thus pursue a career that was STEM oriented. The study engaged 297 FIRST participants, that is, those who had been exposed to STEM at pre-college level and assessed their career choice at university level. The study at the same time assessed learners who had not been exposed to FIRST robots and assessed their career choices at university level. The participants were also required to fill a questionnaire with items related to FIRST robots. From the findings, it was found that most (94%) students who had been exposed to FIRST robots chose courses related to STEM. Out of these, 88% were in support that FIRST robots had a great impact on their choice of STEM related courses.

## **2.6 Theoretical Framework**

According to Lederman and Lederman (2015), a theoretical framework presents an introduction and description (s) of the theory (ies) that explain (s) why the problem being researched on exist. In this study, constructivism and constructionism theories were adopted.

### **2.6.1 Constructivism Theory**

Constructivism theory emanates from Piaget's (1964) cognitive constructivism and Vygotsky's (1978) social constructivism. Piaget (1964) approach under cognitive constructivism noted that the learner is a "lone scientist" who develops knowledge through self-exploration with the teacher's role being provision of opportunities for

the learner to learn for themselves, what was referred to as discovery learning. Therefore, constructivism as driven by Piaget (1964) argues that manipulating artifacts (educational robots in this study) are key for learners in constructing their knowledge. Therefore, educational robots create an environment of learning where learners can interact with their environment and engage with world problems that are real.

Alimisis (2019) was inspired by the theory of constructivism in developing the ROBOESL activities of training and learning for learners at risk of failure and early school dropout. By engaging learners through ROBOESL, their confidence, social skills and self-esteem were rebuilt due to the attractiveness of the learning environment created by ROBOESL. For Afari and Khine (2017), the environment offered by Lego Mindstorms robotics is that of constructivist where learners are presented with the opportunity to manage their self-learning and that where they are capable of cultivating their skills in Mathematics and science. Therefore, educational robotics adopt constructivist approach by enabling learners understand the link between theory and real-life and what is learnt in class with what is real.

Though the theory has been embraced by many scholars in learning, it is not without caution. Kirschner, Sweller and Clark (2006) caution its application for it promotes a style of teaching with instructions that totally lack guidance or with minimal guidance. In this case, learners can become lost and at the same time frustrated. By adopting a constructivist approach, minimal guided instruction style of learning does not consider the importance and framework of working memory in learning (Kirschner *et al.*, 2006). Another caution held by Papert and Harel (1991) is that students have to link their knowledge to objects that are tangible so as to ensure that knowledge is acquired; constructivist styles are not for this learning-allied need. According to Papert and



Harel (1991), learners must possess knowledge by making educational robots or artifacts. There are other concerns as outlined by Ackermann (2001) such as availability of resources and preference of learners. For Ackermann (2001), constructivist approach focuses on cognitive factors only while ignoring other factors such as technology and environmental that contributes to learning.

Despite wide criticisms, constructivism still stands as a commanding theory in the education field thanks to its advantages and global support. For Ackermann (2001), teachers whose approach is constructivist helps their learners in knowledge construction and do not leave the learning responsibility entirely on the learners. The approaches employed in constructivism change learners from the status of passive recipients to active students (Ackermann, 2001). According to Hmelo-Silver, Duncan and Chinn (2007), classrooms under which constructivism is applied have students' interests highly valued and build upon what learners already know through provision of supporting instructions. Therefore, the cognitive load is reduced, expert guidance is provided and learners are assisted in acquiring thinking and acting ways that are highly disciplined while at the same time allowing for creativity. Researchers such as Cummings (2004), Shachaf (2008) and Gibson and Gibbs (2006) advocate for constructivism due to its ability to engage learners in the classroom, its support for diversity, creation of environments that are competitive, development of problem-solving skills, promotion of learning through doing and building of social relationships among students.

From the discussion herein, this study adopted constructivism in developing an educational robot, a form of manipulating artifact (Piaget, 1964), which was key for the learners in knowledge construction. Through the robots, teachers offered learners

with opportunities to engage on explorations that are hands-on and provided tools for learners to construct knowledge in a learning environment. Through the theory, robotics activities were integrated in teaching Mathematics and Physics thus providing the learners to cultivate skills in Mathematics and science. The learners were able to understand the link between scientific and mathematical theory with real life problems.

### **2.6.2 Constructionism Theory**

Papert (1972) developed constructionism theory by stating that students need to create artifacts for practicing what they have learnt in class and to tangibly experience outcomes while being engaged in knowledge construction production. While further discussing constructionism, Papert and Harel (1991) noted that constructionism is simply learning by making. In this case, outcomes in learning can be seen, critiqued and utilized by others and that knowledge construction is through physically practicing skills, beyond intangibly. Through constructionism, arts and design are integrated in the subjects that the students are taught. For Papert (1972), knowledge is grounded in the learning context and it is through products' designing that it is shaped.

Ackermann (2001) further supports constructionism by stating that through designing, thinking and rethinking of products, students learn more, their thinking is sharpened while their knowledge is strengthened, a process that Papert (1972) referred to as development. Ackermann (2001) added that constructionism approach helps learners to understand formation of ideas resulting from cognitive learning. Therefore, constructionism learning occurs physically and tangibly, not just cognitively as constructivists believe.

Papert and Harel (1991) while advancing constructionism noted that its focus is more on technology. Therefore, constructionism involves learners constructing tangible products and making them visible as a way of knowledge construction. This is the aspect that Papert and Harel (1991) introduced as “object-to-think-with”. Through “object-to-think-with”, learning takes place when projects exist as yields of learning outcomes symbolizing abstract knowledge. The term also demonstrates the notion that learners converse with objects during the design stage; therefore, knowledge is not just built based on previous knowledge in the mind of learners, but has to exist tangibly as evidence of learning.

Through constructionism theory, learners are allowed to interact with robots and their basic operations after which they are presented with tutorials with examples and visualizations to help them understand how the robots are applicable in teaching science and Mathematics related topics. Learners are then allowed to develop their own activities, referred to as games, by modifying the robots. While they are developing their own projects, the instructor’s role is to offer guidance and provide complex concepts on a personal level (Papavlasopoulou, Giannakos & Jaccheri, 2019).

Kynigos (2015) presented constructionism theory as a theory of learning and design. Constructionism should not just be thought of from a scientific perspective, but should also be viewed strategically since it intervenes and pushes for change in conventional practices of education. Kynigos (2015) further noted that constructionism is relevant in the modern world due to technological evolution that has presented objects that can be tinkered with and tools that can be collectively applied in teaching. Traditional science and Mathematics are given meaning through representations that can be

utilized in models creation and those which can be manipulated, visualized and connected.

The theory was extended by Papert (2020) who developed the LOGO language of programming and the “Turtle” robotics. From the project, Papert (2020) opined that learners learn through doing that which allows them to construct their knowledge through interaction with objects. Therefore, students create their conceptualizations through real-life experiences acquired from the actual world. Papert (2020) went further and demonstrated that accomplishment of learning occurs when a learner creates a robotic structure since the process of construction enhances the learner invent from the onset techniques and throughout the working of the robots in problem solving. Therefore, the perception in Papert (2020) is more advanced with learners engaging in knowledge and meaning construction through toying with an object that is tangible.

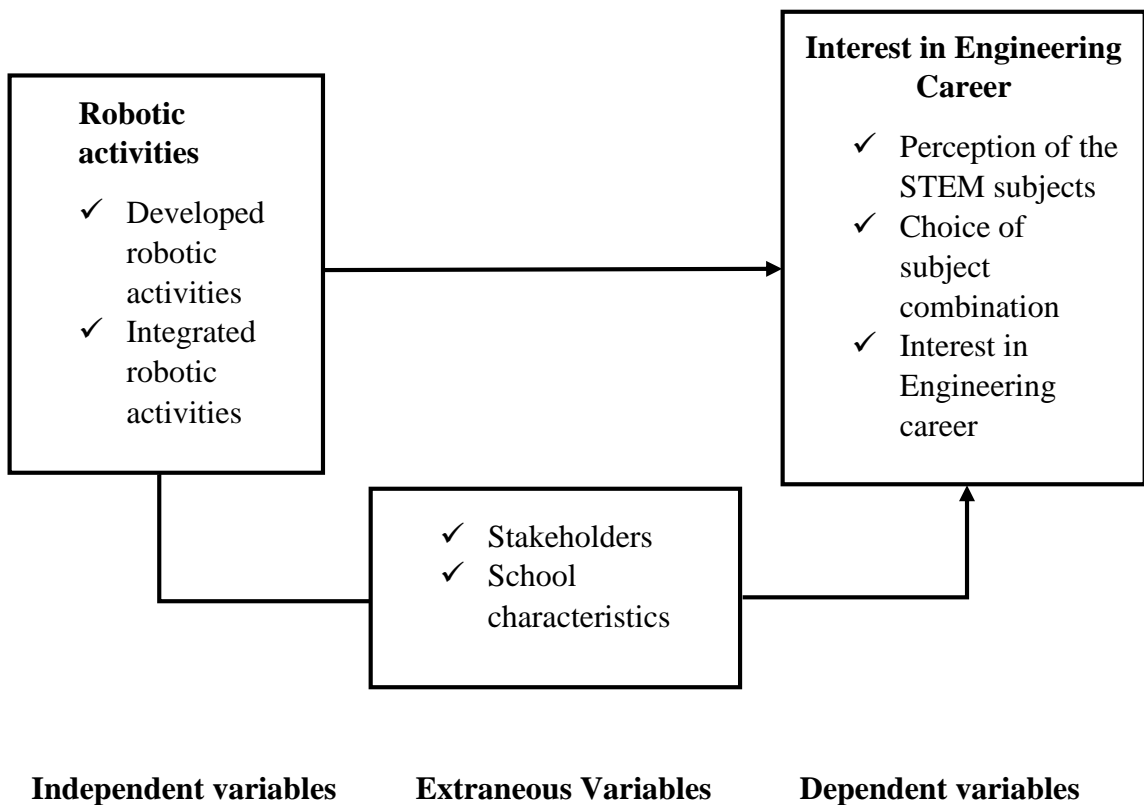
Ackermann (2001) hails constructionism since it allows educators to rethink education, imagine learning environments that are new and integrate new technology, media and tools at the learner’s service. Constructionism reminds educators that learning is more than information acquisition or submission to ideas of other people. Learning is about allowing the learners to express themselves, find their own voice and exchange ideas with others.

In this study, constructionism was adopted as a way of learning by constructing and called for understanding through construction. Since the theory advocates for learner centered and discovery learning where knowledge that is already acquired will be utilized in acquiring extra knowledge, it was more suitable in guiding the development

of robotic activities based on the designed educational robot and integration of the activities to secondary school STEM subjects.

## 2.7 Conceptual Framework

A conceptual framework gives a broader understanding of the phenomenon of interest in a study (Varpio *et al.*, 2020). From Figure 2.1 the relationship between various variables is shown. It shows that the independent variables will have a direct influence on the students' career choice.



**Figure 2.1: Conceptual Framework**

For this research the independent variables were robotic activities which included the general developed robotic activities and the integrated robotic activities. The independent variables have a direct impact on the student interest towards Engineering career pathways as indicated in Figure 1.1. When the learners interact with the robotic

activities their perception towards Physics and Mathematics changes. The extraneous variables included stake holders and the school characteristics. The Stakeholders like teachers, parents among others can influence the students' career choice as they interact with them. School characteristics such as facilities, category (the ranking and gender of the school) could also influence the outcome of this study. These extraneous variables were controlled by conducting the experiment in an independent environment. The experiment for all the learners was done at Murang'a University of Technology in form of workshops organized in their environment. Interest in the Engineering Career was the dependent variable in this study. The change of perception of Physics and Mathematics, Choice of subject combination toward an Engineering career and the indication by the learners that they would actually choose an Engineering career were the key indicators.

## **2.8 Summary**

From the literature reviewed, educational robots that are in existent are of various designs and functionalities with different tools in programming. However, literature reveals that the most popular robotic kits are of LEGO Mindstorms (Bagnall, 2014). Moreover, the design of educational robots should adopt readily available materials with easy to understand programming language (Vandeveldel *et al.*, 2016; Chomyim *et al.*, 2015; Kim *et al.*, 2019). This will ensure that the design yields low cost and easy to use and modify robots in education. Literature was also reviewed on development of robotic activities. From the literature reviewed, activity development should involve taking the learners through the fundamental aspects of a robot and then presenting them with challenges that they are required to solve (Chen & Chang, 2018; Scaradozzi *et al.*, 2020). Through this, they are able to understand the functioning of

a robot. By developing activities, students are able to figure out how a challenge would look like, manipulate the robot to achieve a solution and also improve the robots for efficiency and accuracy (Screpanti *et al.*, 2018).

The activities developed should relate to real-life experiences and should also motivate, enhance confidence and spark interest among the learners (Ziaeeefard *et al.*, 2017). Upon developing an educational robot, literature revealed that the robot should be integrated into teaching different concepts in various disciplines. Integration should follow various themes and should be in line with the school curriculum so as to upgrade the learning of the subjects (Ntemngwa & Oliver, 2018; Scaradozzi *et al.*, 2015). From the review of previous literature on impact of educational robots, it is evident that use of educational robots in STEM help learners has a glimpse of problems in STEM that are real-life (Eguchi, 2016). This makes them feel like scientists in the course of learning which in turn affects their career choices in the future (Tiryaki & Adguzel, 2021). Further, educational robotics provides enormous benefits to students at different levels. Some of the benefits include; development of critical thinking skills, STEM process skills, acquiring skills problem solving, growing in creativity, persistence, social interactions, and skills in teamwork (Chen & Chang, 2018; Goh & Ali, 2014). Two theories, constructivism and constructionism, that still stand as commanding in education will guide the study. The theories advocate for the reduction of the cognitive load, provision of expert guidance, assisting learners in acquiring thinking skills and allowing for creativity through interacting with educational robots.

There is inadequate research on robot designs made by the researchers. Most studies reviewed use already existing robotic designs for research purposes. Most of the

researches reviewed have used robotic activities for competition purposes and not for purposes of enriching the formal learning process. Therefore, the students after participation in the robot competitions, may not see the connection between the robotic activities and the subject they learn in school. From the literature reviewed the findings reveal that the issue of integration of the robotic activities to STEM topics has not been realized though recommendations has been made in that regard. Most of the researches do not do follow up on the choice of the career made after exposure to the robotic activities.

This research addressed the gaps by fabricating low-cost robotic car and arm which included a hybrid of Arduino and Raspberry pi microcontrollers. The hybrid design brought in the benefits of both microcontrollers thereby improving the capabilities of the educational robots for secondary school students. Robotic activities were then developed and implemented using the active learning cycle. This research also integrated the developed robotic activities to the subjects learnt in Form 2 to make STEM related subjects more appealing. The research exposed form 2 secondary school students to integrated robotic activities and examined the effects the exposure had on perception of Physics and Mathematics. The research further assessed the impact of the exposure to students' interest in Engineering career pathways. This was done by administering questionnaires to the students before and after exposure and establishing whether there was a change in terms of the learners intending to pursue Engineering career pathways. There was also a follow up to establish whether the students who had indicated they would choose Physics as the key subject towards an Engineering career did so in preparation of the career.



## **CHAPTER THREE**

### **METHODOLOGY**

#### **3.1 Introduction**

In this chapter, the procedures of carrying out the research are described. The research design, research process, educational robot fabrication, the population and their context are described, as well as the methods of collecting data to be employed. The data analysis procedures used in the study are explained, as well as ethical considerations.

#### **3.2 Research Design**

According to Kumar (2018), research design can be defined as an overall strategy for conducting research that helps to conceptualize an operational plan in a reasonable and logical manner so that the research problem is efficiently handled. Different components of a research are integrated in research design to ensure that the research problem is effectively addressed (Andrew, Pedersen & McEvoy, 2019). A research design constitutes the outline for data collection, measurement and analysis (Patten & Newhart, 2017).

In this study, quasi-experimental research design was adopted. According to Cook (2015), quasi-experiments usually test the causal consequences of long lasting treatments outside the laboratory. The main purpose of the experiments done in this design is to establish whether a treatment made some difference in a particular outcome. The effect of a treatment condition as compared to a specific comparison condition is the difference in the outcomes between what happens after a treatment and what would have happened without the treatment (Reichardt, 2019).

In the present study, a 3-week workshop was conducted at Murang'a university of technology where learners were exposed to educational robots and robot related activities. The activities were integrated in Physics and Mathematics topics with the aim of investigating their effect in learning of the subjects. The study further sought to establish the overall impact of the exposure to robots and robotic activities on the interest in Engineering career pathways. The researcher collected quantitative data through administering questionnaires before and after exposure after which a comparison of the results was done. Additionally, teachers were also exposed to the robotic activities after which interviews were conducted and qualitative data obtained from their responses.

Quantitative and qualitative was employed in data collection in since the timing between the quantitative and qualitative stages was “concurrent”. Therefore, the collection of qualitative data supported the quantitative data that was more dominant (Teddlie & Tashakkori, 2009). Thus, qualitative research was embedded into quantitative research to support the elements of the experiment. Since quantitative data is dominant in this study, qualitative data obtained through interviews was used to establish whether the experimental results are meaningful and whether deviations might exist in the experimental process.

### **3.3 Study Variables**

#### **3.3.1 Independent Variable**

The independent variables were the educational robots and robotic activities integrated in Physics and Mathematics.

### **3.3.2 Dependent Variables**

The dependent variables were the perception of the subjects and the interest in engineering career pathways after exposure.

### **3.4 Target population**

Target population refers to all the members who meet a particular criterion specified for a research investigation (Alvi ,2016). The researcher obtained data about the target population from Murang'a County Director of education office. According to Muranga' County (2021) records, there were 2, 478 Form 2 students enrolled in the secondary schools located in Kangema Sub-County, forming the study's target population. Secondary school Physics and Mathematics teachers from Murang'a County also formed part of the target population as key informants. The participants were found to be fit in providing data required to address the research objectives. For instance, the form 2 students were included since were included in that it is at this level where they select subject combinations towards their career pathways. The teachers were included because they play a great role of guiding the learners in the learning

### **3.5 Sampling Techniques and Sample Size**

#### **3.5.1 Sampling Techniques**

In order to understand the impact of robotic activities, the researcher used both probability and non-probability sampling techniques. Probability sampling is a technique where a sample is selected using random selection so that each element in the population has a known chance of being selected while non-probability sampling is a technique where some units in a population are more likely to be selected than others (Bryman,2012).

The non-probability sampling employed in this study was quota sampling technique in selecting schools in Kangema sub county. The categories of schools in Kangema sub-county include Mixed schools, Boys' schools and girls' schools. Quota sampling was employed in determining the schools that would represent the various categories (Meng, 2013).

The study employed purposive sampling in settling for form 2 students as they prepared to select their subject combinations towards their career pathways. Simple random sampling technique was employed to select the Form 2 students for the schools sampled. This allowed the Form 2 students in each School to get an equal chance of getting selected. Probability sampling technique has less risk of bias and therefore enables one to make inferences from information about a random sample to the population from which it was selected (Bryman, 2012).

The technique employed to select the Physics and Mathematics teachers for participation in this study was purposive sampling. Under purposive sampling, the intention was to subjectively select participants of a study based on the judgment of the researcher (Acharya *et al.*, 2013).

### **3.5.2 Sample Size**

A sample refers to a portion of the entire population that takes part in a study (Ritchie, Lewis & Elam, 2003). According to Mugenda and Mugenda (2003), a sample size ranging from 10-30% of the entire population is recommended. For this study, 270 students were selected from Kangema Sub County, Murang'a County. This forms 10.9% of the total population which is within the recommendations by Mugenda and Mugenda (2003). The study also involved 10 Physics and Mathematics teachers as

key informants from the schools where learners were selected. The Form 2 students were selected in this study since it is at the end of this level that they choose subject combination in preparation to a career pathway. Other participants included the Physics and Mathematics teachers since they are the ones who taught the students in the old conventional methods and played a great role as informants in this study.

The participants sampled were taken through three-day workshop sessions, organized at Murang'a university of Technology and facilitated by the Royal Academy of Engineering. This was done in group of 30 students per session for seven sessions. The workshops were carried out on Saturdays in order to avoid the disruption of their weekly lesson. Additionally, Saturdays provided ample time for the exposure from morning to evening. The participants were taken through robotic activities in groups of three to five as they learnt the various concepts in Mathematics and Physics. They gave their feedback before and after going through workshops, on the impact of the activities through interviews, pre-exposure and post-exposure questionnaires, pretest and post-test exams.

### **3.5.3 Sampling procedure of the students**

Cochran (1963) formula for sample size calculation was used in determining the sample size for the study. According to Cochran (1963):

$$n = \frac{Z^2 pq}{e^2}$$

Where n is the desired sample, Z is the abscissa of the normal curve (1.96 at 5%), e is the precision level (5%) and p is the estimated proportion of the number of students possessing attributes towards engineering career pathways (those likely to study Physics after Form 2) and q=1-p. According to CEMASTEIA (2020), the proportion

of students who studied physics and were examined at the national exams in Kenya stood at 27%, therefore p will be equal to 0.27 for this study. The sample size can therefore be computed as:

$$n = \frac{1.96^2 \times 0.27 \times 0.73}{0.05^2} \approx 303 \text{ students}$$

However, Israel (1992) noted that for finite population sizes, the sample size should be corrected using the formula:

$$n_0 = \frac{n}{1 + \frac{n-1}{N}}$$

Where  $n_0$  is the adjusted sample size for the study,  $n$  was the computed sample size according to Cochran (1963) and  $N$  is the population for the study. According to Kangema Sub-County Ministry of education report, there are 2471 students in Form 2 in the Sub-County, therefore,  $N=2471$ . The adjusted sample size is therefore computed as follows:

$$n_0 = \frac{303}{1 + \frac{303-1}{2471}} \approx 270 \text{ students}$$

### **3.6 Data Collection Instruments**

This study employed both quantitative and qualitative approaches. It used quantitative data from the Student Interests towards Engineering Career Questionnaire (SIECQ) and qualitative data from individual teachers' interviews, to answer the research questions that were posed for this study. The quantitative part of this research examined students' interest in Engineering after exposure to the organized sessions by the use of data from the questionnaires. Data was also collected through pre-tests and Post-tests. The qualitative part of research investigated teachers' opinions on robotic

learning activities that will promote the students' interest in Engineering careers. This data was collected from the individual teachers' interviews.

### **3.6.1 Questionnaires**

Questionnaires were part of the instruments used for data collection in this study. The questionnaires were constructed for quantitative data collection from the Form 2 students. According to Williamson (2013), questionnaires are advantageous since they allow a researcher to get data accurately and enhanced uniformity, due to uniform items, in response by a large number of respondents at the same time. The researcher also obtains data in a cost effective manner and at the same time in a more reliable manner. Through questionnaires, Rhind, Davis and Jowett (2014) noted that it is also easier and faster to reach out to a good number of respondents in time. The questionnaires were coded to ease the process of tracing them after completion.

The questionnaires for this study had seven parts consisting of both open and closed ended questions. The close ended questions were in the form of a Likert rating scale. Part A of the questionnaire comprised of questions intended to capture personal information of the participants; Part B contains questions on learners' background in Physics and Mathematics activities; Part C contained questions learners background in robotics; Part D dealt with robotic activities; Part E included integration of the activities to science subjects; Part F consisted of questions establishing the impact of robotic activities to learners' career pathways choice and Part G which contained questions on career pathways choice. The questionnaire is shown in appendix C.

### **3.6.2 Pre-tests and Post-tests**

For purposes of this study, three tests were prepared and administered to the Form 2 students at different timings. The examinations were set in the required standard and

testing various domains. The pretest was administered just before the introduction to robotics, the first post test was administered after the introduction to robotics, and the second posttest was administered after the completion of the exercise. The pretest and posttest exams used for this study are attached in Appendix E.

### **3.6.3 Interview Schedule**

According to Kumar, (2012) interviews can be defined as face to face interaction between one or more individuals. Wilson, (2010) observed that interviews have the capability of engaging participants in verbal or non-verbal communication thereby providing accurate information with much flexibility in posing and answering of the questions. Roulston (2011) observed that conduction of interviews was characterized with challenges related to setting up of venue, administration and transcribing the interview. He further observed that the process of data analysis from interview schedules is time consuming and can be influenced by personal emotions and opinions. Doody and Noonan (2013) concluded that the use of predetermined group of questions which has the same wording in the interview schedule could be used in minimization of bias during the interview. Interview schedules were employed in this study to obtain the expert opinions of the teachers in the STEM subjects on the suitability of the developed and integrated robotic activities. The schedules were also used for triangulation purposes. In this research, 10 Physics and Mathematics teachers from secondary schools in Kangema Sub-County, Murang'a County were interviewed using a structured interview schedule illustrated in Appendix D.

### **3.7 Validity of the instruments**

Validity of research is the extent to which scientific research method requirements are followed (Mohajan, 2017). Sullivan (2011) added that validity is about what is



measured by a research instrument and how well it is measured. To ensure validity, questionnaires were first scrutinized and approved by a team of experts. Then after pilot study was carried out the results were discussed by researcher and the experts. Essential responses on each item from each expert were evaluated by a content validity ratio, and those meeting statistical significance values were retained. The instruments were then adjusted by incorporating the experts' opinion.

### **3.8 Reliability of the instruments**

Reliability is the consistency of a test, survey, observation, or other measuring device and describes the extent to which instruments produce consistent results in similar conditions over time (Gidron, 2020). Reliability of instruments of research ensures that one has faith in the data gathered using the instruments (Kimberlin & Winterstein, 2008). Fitness of data for analysis was determined before conducting statistical analysis, by computing Cronbach's Alpha value. The Statistical Package for Social Sciences (SPSS) version 25 was used to test for reliability. To ensure reliability of the questionnaire, pilot studies were conducted. Cronbach Alpha reliability coefficient of 0.7 was used as the rule of thumb (Kaneoka *et al.*, 2013). The Cronbach alpha coefficient was greater than 0.7 (see Table 3.2); therefore, the scales of measurement used in this research were deemed reliable.

**Table 3.1: Reliability Statistics**

Cronbach's Alpha	N of Items
.728	66

### **3.9 Piloting of the Instruments**

The research instruments should be pre-tested to ascertain suitability and workability of the questions and whether the participants could respond as expected (Hilton, 2017).

For purposes of the pre-test, a small number of participants were selected to establish the appropriateness of the research instruments and also find out whether the questions were clear (Dikko, 2016). A post-questionnaire interview was thereafter conducted to check whether the participants clearly understood the questions. In consultation with the supervisors, the researcher used these responses to modify the instruments to enhance reliability and validity by ensuring expert judgment. The testing of the instruments was done on a group of form 2 learners that had similar characteristics to the group that would be selected in the actual researched. Hence, before the actual data collection, twenty-seven (27) questionnaires were distributed to form two students in a secondary school within Murang'a County that was not sampled to take part in the study. This followed recommendation by Hertzog (2008) who stated that 10% of the study's sample as adequate for a pilot study.

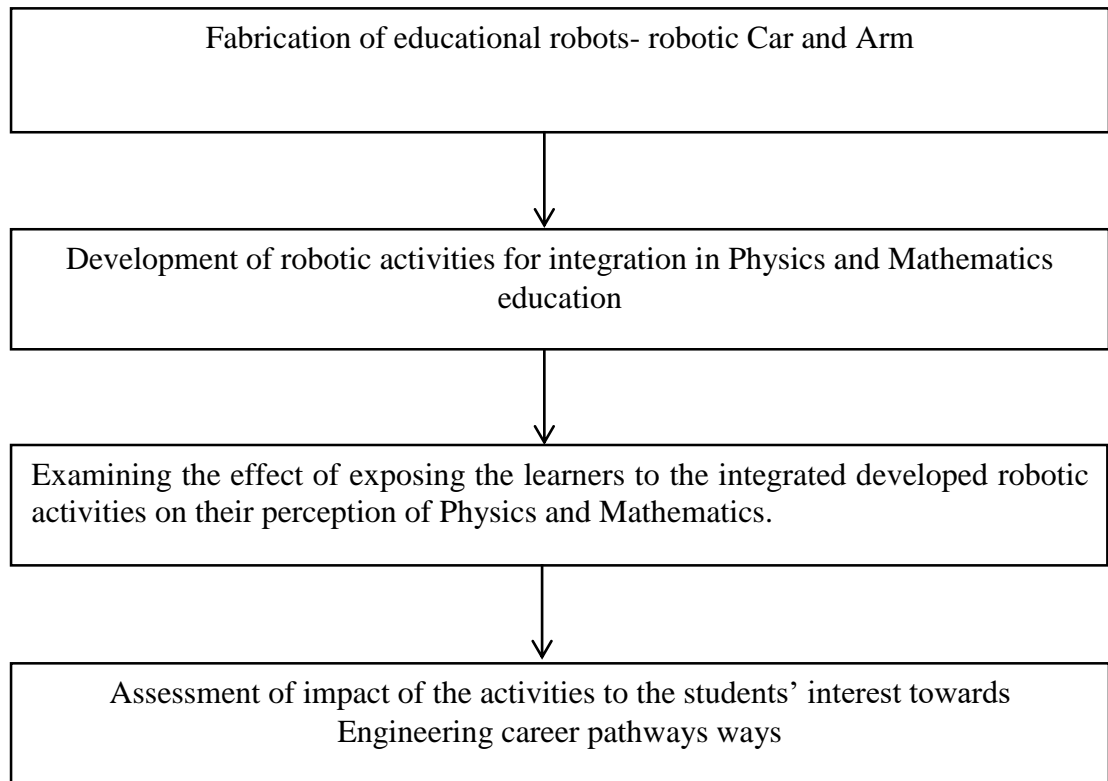
### **3.10 Data Collection Procedures**

Before embarking on data collection, the researcher sought a letter of introduction from Murang'a University of technology (see Appendix K). Further, a research permit was sought from the National Commission for Science, technology and Innovation (NACOSTI) to undertake the study (see Appendix L). The researcher selected 270 form 2 students from the different school categories with the permission of the principals of the respective schools and with the help of the Physics and Mathematics teachers from the schools. The study was done between June 2021 to December 2021. During this period workshops were organized at Murang'a University of Technology with the permission of the university administration. The workshops were conducted with the assistance of four Murang'a University of Technology Engineering Department Technologists, six Bachelor of Technology and four Bachelor of

Technology education students. The secondary school students were issued with pre-exposure questionnaires and pretest exams before the commencement of the workshop and upon reporting to the university. They were then introduced to educational robot's functionality and general robotic activities. After familiarizing with the educational robot and related activities, integration was implemented into teaching various topics in Mathematics and Physics. The learners were exposed to the robotic activities for a period of three weeks. The first posttest exam was issued on the second week of the exposure to the educational robot. Learning using the educational robot proceeded for the third week after which a second posttest exam was issued. The post exposure questionnaires were then administered at the end of the workshop. Interviews for the teachers were also conducted at the end of the workshop. A follow up observation was done 6 months after the completion of the workshops and after the learners joined Form 3. The workshops were conducted under strict adherence to COVID-19 protocols which was a challenge in that the researcher had to restrict the number of participants per session during the workshops. The researcher and his team were extra-vigilant in the handling of robots and other items in order to reduce chances of COVID-19 infections.

### **3.11 The Research Process**

A research process refers to a systematic manner on how a research is approached in a study area so that worthwhile knowledge is produced (Williams, 2007). The research process involved four major steps as shown in Figure 3.1.



**Figure 3.1: Research Process**

### **3.11.1 Fabrication of Educational Robotic Car and Arm**

In this research, two robots were fabricated and implemented which included a robotic car and robotic arm. In order to assemble the robots, various materials were required. The chassis and the robotic arm parts were designed and printed using a 3D-printer. The design part of the robotic kit included system designs sequence presented and block diagram illustrations. The educational robots consisted of two parts, namely: the system hardware and the system software.

### **3.11.2 Selection of Hardware Components Used**

The hardware components for purposes of fabrication were selected based on the following factors:

**i. Cost and availability of components**

The components employed in the design of the robot cars and arm should be affordable in terms of cost and also available (Román-Ibáñez *et al.*, 2018). The recycled materials and locally available materials utilized for the fabrication lowered the entire cost of construction. In this study the chassis, the robot arm parts and the robot cover were printed from a locally available 3D printer. The printing filament was locally available which made the printing of parts easier.

**ii. Weight and durability of materials to be used**

The components used in this study were light in weight but strong in order to enhance the flexibility of the robot designed. This consideration followed Ng *et al.*, (2021) who indicated that robots should be lightweight for portability and optimization of power consumption.

**iii. Current and voltage ratings**

There are different components used in the building of the robots. The components have different power ratings. The supply source must accommodate all these components so that the robot can function effectively. The right batteries must be selected.

In fabricating the robotic car and arm some the materials required are highlighted in Table 3.2;

**Table 3.2: Materials required for the Fabrication of the Robots.**

Materials required		Materials required	
1.	Robot car Chassis (printed by a 3D printer)	13.	Screws
2.	Side and front plates (printed by a 3D printer)	14.	Nuts
3.	Robotic arm parts-base and links (printed by a 3D printer)	15.	Ultrasonic sensor
4.	Wheel support plate (printed by a 3D printer)	16.	Infrared sensors
5.	Servo motors and direct current motors	17.	Push buttons
6.	Motor driver circuit	18.	Buzzer
7.	Car Wheels	19.	Light Emitting Diodes
8.	Castor wheels	20.	Resistors
9.	Basic electronics boards	21.	Jumper wires
10.	Arduino Uno microcontrollers	22.	USB cables
11.	Bolts and nuts	23.	Batteries
12.	Robot car Chassis (printed by a 3D printer)	24.	Battery holder

**3.11.3 Low-Cost Robot Fabrication Overview**

This section presents how the robots were fabricated, assembled and the robot platform developed for applications in educational robotics. The robots consisted of 2 main parts which included; the hardware and the software. The main parts of the robots were made of recycled plastic materials. These included the Chassis, the cover for the robotic car, the base and the links of the robotic arm. The designed robot car had a diameter of 150 mm, a height of 15 mm and a weight of approximately 400 g. In this study, two robots were adopted which consisted of a robotic car with line following and obstacle avoidance functions and a robotic arm.

### **i. Robot Car-Line following and obstacle avoiding functions**

The robot car is a mobile robot which moves autonomously based on the set conditions. The robot car fabricated for this study had a line following and an obstacle avoidance functions.

**A car with line following functions** can detect the presence of a black line and follows it (Antony *et al.*, 2020). The path is therefore predefined and for this study a black line is drawn on the floor to be followed by the robot. The robot senses the line with the help of the Infrared Ray (IR) sensors placed under the robot. Once it detects the line, the data is transmitted to the Arduino microcontroller for further processing. The microcontroller then sends a signal to the motors connected to the wheels to either initiate movement of the car or stop it.

**An obstacle avoidance function** of the robot uses ultrasonic sensors to detect an obstacle (Kim *et al.*, 2007). When the robot is moving along a desired path, the ultrasonic sensor transmits ultrasonic waves continuously from its sensor head. Once an obstacle comes ahead of the sensors mounted in front of the robot car, the ultrasonic waves are reflected from an object and the signal communicated to the Arduino microcontroller. The Arduino microcontroller sends signals which then control the motors left, right, back, front, depending on ultrasonic signals received.

### **ii. A robotic arm**

A robotic arm is a programmable device that is designed to manipulate objects in a manner resembling that of a human arm (Olawale *et al.*, 2007). It is made up of links connected by joints allowing either rotational motion or translational displacement. Servomotors are connected around the joint area and programmed to attain the

required movement of each link. The end of the manipulator is referred to as the end effector or the gripper and is similar to the human hand. This enables the arm to pick and place something as programmed.

#### **3.11.4 Robotic Car**

A robotic car was fabricated that would move autonomously. The first exercise in the robot fabrication included 3D drawing in the AutoCAD and printing of the chassis, the robot covers and the structural support elements for the parts that made up the robot using a 3D printer. This was followed by an assembly of the electronic circuit for the infrared sensors, Ultrasonic sensors and the Arduino microcontroller.

##### **a. Robot Car Construction**

The robotic car fabrication process included the 3D design of the Chassis and the body of the car. This was followed by the selection of the appropriate sensors, motors and microcontroller. These components are discussed and include;

##### **i. Chassis and Body**

In the robot fabricated a plastic chassis was used since it is light in weight and strong. Additionally, various components for instance wheels and motor could be easily attached. The chassis was designed through 3-D drawing and exported to the 3-D printer for printing in a locally available printer.

##### **ii. Motor and Wheels**

Direct Current motors were used for the robot design providing a high torque and efficiency. Direct Current motors are simple and easy to install onto the chassis. The motors rotate the robot clockwise or anticlockwise depending on how they are programmed. Electrical energy from the power source is converted into mechanical



energy by the motors which are used to drive the wheels. Two medium sized wheels and a caster wheel were attached at the front for easier and smooth movement. This is the most common combination for wheeled robots. The dc motor is programmed so that it works as desired by the programmer and in connection with the sensors. Figure 3.2 shows the direct current motor and the wheel attached to it.



**Figure 3.2: Direct Current Motor and Robot Wheel**

The direct current motor employed in this fabrication had the following specifications:

- Operating voltage: 1.5 to 3V
- Max RPM (No-Load): ~12000
- Stall current (3V): ~2.5A
- No load current (3V): ~800mA
- No load current (1.5V): ~560mA
- Weight: 13.5g
- Motor body dimensions: 28.8 x 19.8 x 15.6mm
- Shaft dimensions: 8 x 1.9mm

### iii. Sensors

**An infrared sensor** is an electronic device. In its operation it emits in order to detect some specific characteristics of the environment surrounding it. It can measure the heat of an object as well as detects the motion. The output of the sensor is digital signal and therefore it is easy to interface with any microcontroller like Arduino and Raspberry Pi among others. It comprises of Infrared emitter and receiver at the front of module, whenever there is object blocking the infrared source, it reflects the infrared and the receiver get it and the signal go through a comparator circuit on board. It is compatible with 5V or 3.3V power input. The infrared sensor used in the fabrication of the robot had the following specifications:

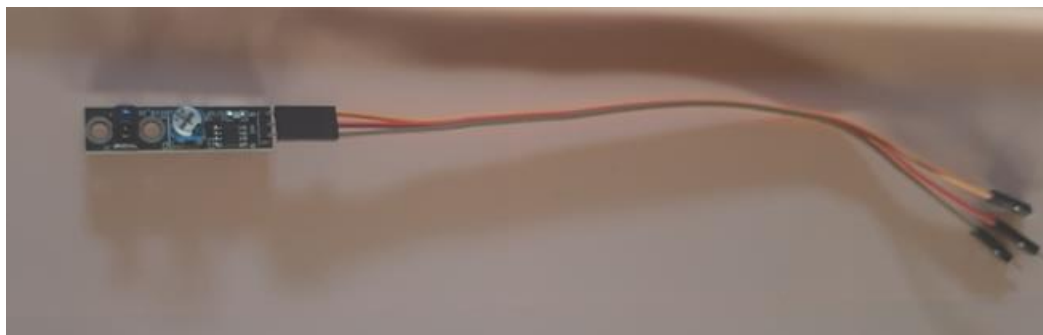
- Input Power: 3.3V or 5VDC.
- 3 pin interface which are OUT, GND and VCC:
  - OUT is digital output pin from sensor module
  - GND is where you connect to your controller ground, or 0V.
  - VCC is the positive supply, connect to either +3.3V or +5V.
- Two LED indicators, one (Red) as power indicator, another(green) as object detection indicator.
- Obstacle detection range: 2cm to 10cm
- Adjustable sensitivity with on board potentiometer, this translate to adjustable detection range.
- Detection angle: 35 degree
- Small size makes it easy to assembly.
- Single bit output.
- Compatible with all types of microcontrollers.

- Dimension: 3.1cm x 1.5cm

**Ultrasonic sensors** are sensors which emit short, high-frequency sound pulses at regular intervals. They disseminate in the air at the velocity of sound. When they hit an obstacle, they reflected back as an echo signals to the sensor. It then calculates the distance to the obstacle based on the time between transmission and reception of the echo. In this study HC-SR04 ultrasonic sensor was used. It uses sonar to determine distance to an object like bats or dolphins do. The specification of the ultrasonic sensor used include:

- Power Supply :5V DC
- Quiescent Current: <2mA
- Effectual Angle: <15°
- Ranging Distance: 2cm – 500 cm/1" - 16ft
- Resolution: 0.3 cm

After the choice of the sensors in this study, programming of the infrared sensors and the ultrasonic sensor followed in order to achieve line following and obstacle avoidance functionalities. The infrared sensor and the ultrasonic sensor used are shown in Figures 3.3 and 3.4 respectively.



**Figure 3.3: Infrared Sensor**



**Figure 3.4: Ultrasonic Sensor**

### **The Line Follower Robotic Function**

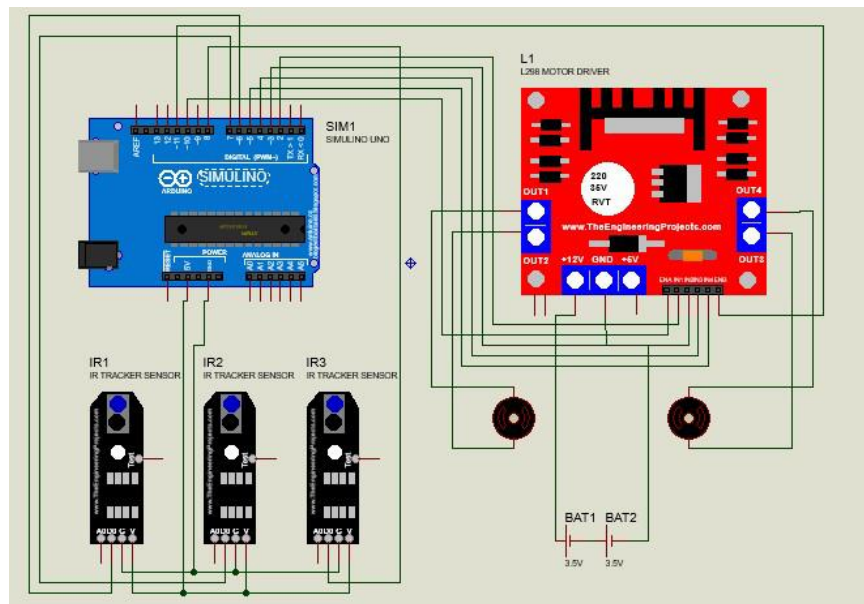
The robot car was fabricated such that through the sensors it could identify the colour on the prepared surfaces. For this design a black line was drawn on a block board of which the car would follow and not any other colour. The path designed for the robotic car is shown in Figure 3.5.



**Figure 3.5: Robot Black Path**

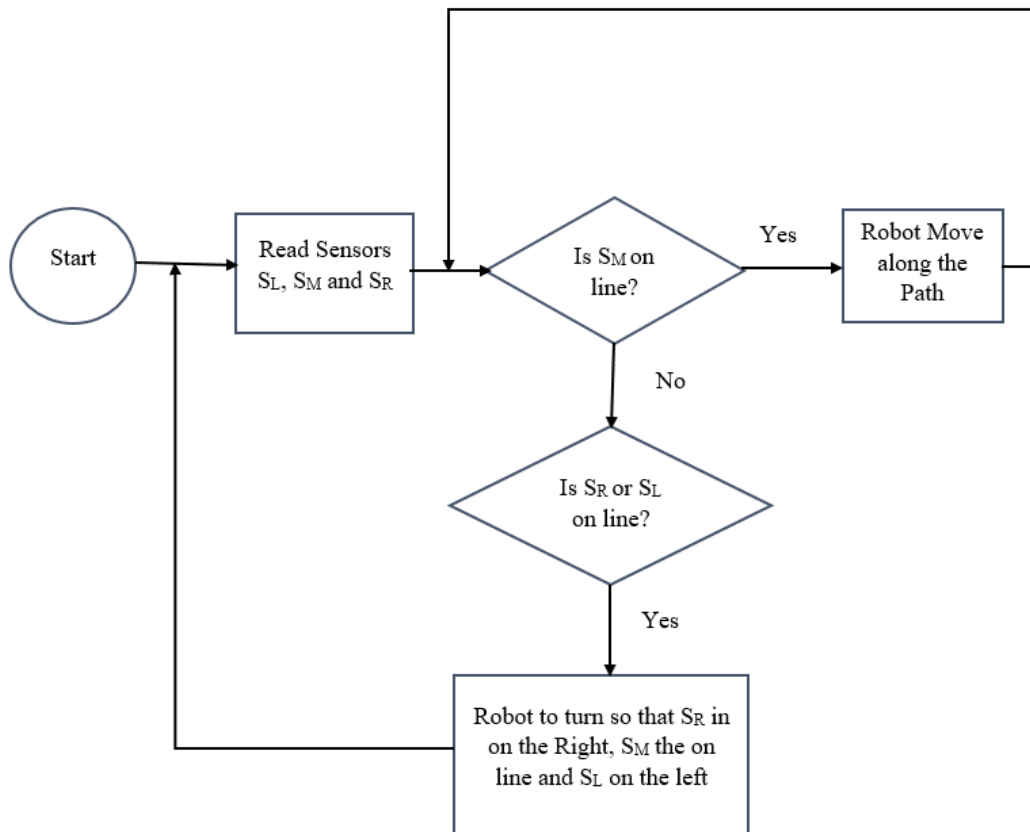
In order to detect the black line, three infrared based tracking sensors were used. Once the sensors detect surface colour, the right and the left motors are either activated or deactivated in preparation of following the pathways.

The sensors send information about the robot's present location to the Arduino microcontroller. The microcontroller on the other hand instructs the motors to move the robot to the required location and stop at the end of a black colour pathways. The wiring diagram is illustrated in Figure 3.6.



**Figure 3.6: Line Follower Wiring Diagram**

The flow chart for the line following function is shown in figure 3.7 The programme for the line following function of the robot is given in appendix J



**Figure 3.7: Flow Chart for the Line Following Robot**

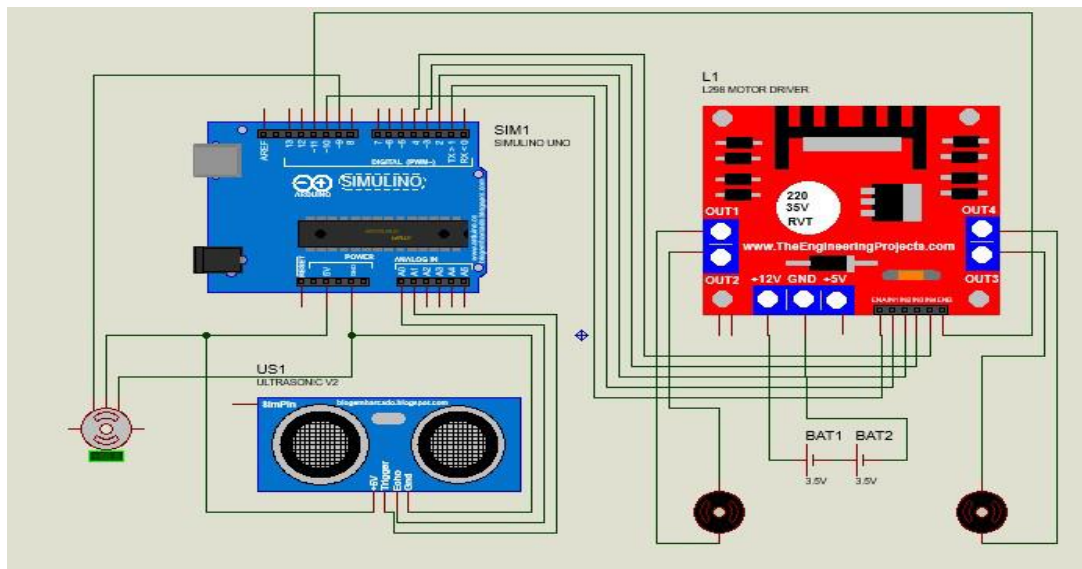
In the line following function, the position of the three sensors is checked. Sensor  $S_L$  should be on the left, Sensor  $S_M$  should be at the middle and Sensor  $S_R$  should be at the right. Whenever  $S_M$  is at the middle the robot will move along the line. Otherwise the robot will turn to the right direction and continue moving along the line.

### **The Obstacle Avoiding Robotic Function**

The obstacle avoidance function of the robotic car was achieved by the use of Ultrasonic sensor in order to measure the distance in front of it as it moves. The Ultrasonic sensor has a transmitter and a receiver module. When a signal is sent from the transmitter it hits the obstacle to be avoided, it is reflected and detected by the receiver. The signal is then converted to distance through the following formula;

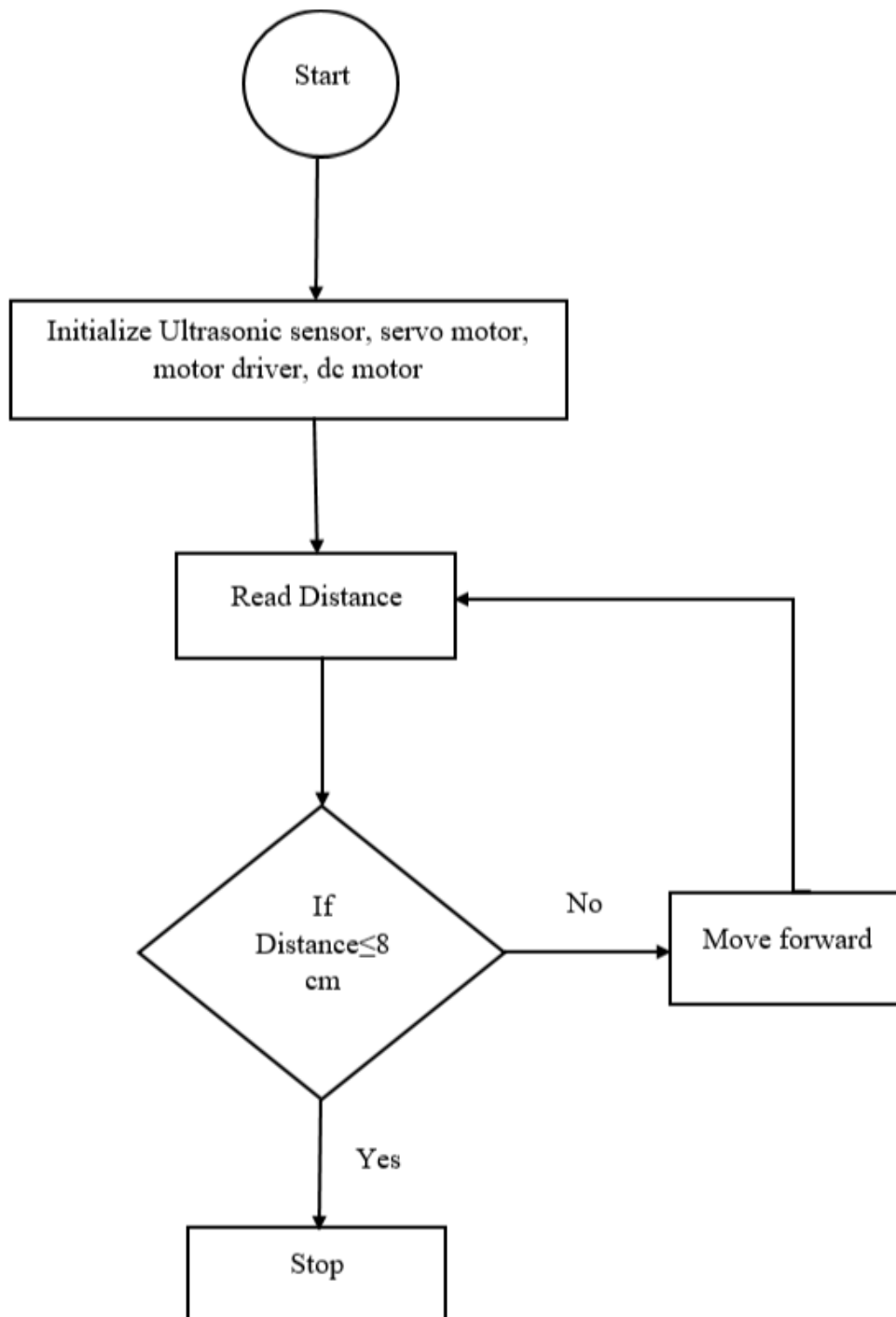
$$Distance = \frac{Speed \times Time}{2}$$

The shortest distance between the robot and the obstacle is set. As the distance reduces, the robot interprets through the microcontroller that as the presence of an obstacle. As soon as the set distance between the obstacle and the robot is detected, the car stops and the checks the next instruction guiding the next direction of motion. The ultrasonic sensor has four pins, two for power (Ground-GND and Common Collector Voltage-VCC) and two for signals. (Echo and trigger). The wiring diagram is illustrated in Figure 3.8.



**Figure 3.8: Wiring Diagram for an Obstacle Sensor Robot**

The flow chart on the robot operation in the obstacle avoidance function is shown in Figure 3.9 while the programme for the obstacle avoidance robot is shown in Appendix I.



**Figure 3.9: Flow Chart for the Obstacle Avoidance Robot**

During programming the sensors and the motors are initialized. For this study a distance of 8cm was set for avoidance of the obstacle. The robot will continue moving until a distance of 8 cm is calculated after which the robot stops.

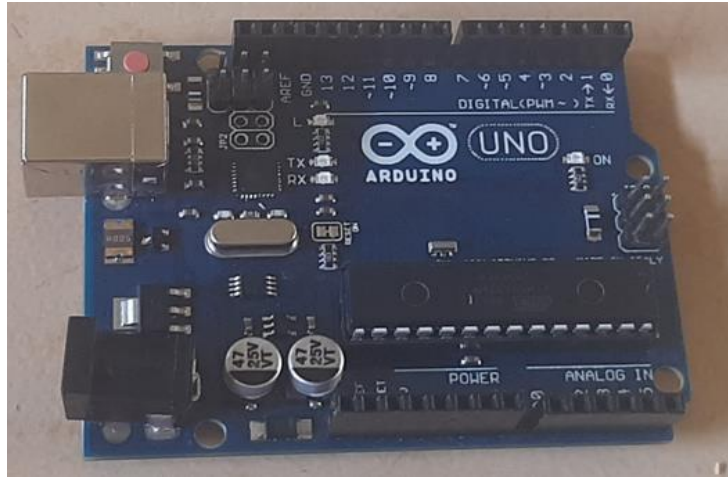


## **The Arduino Microcontroller**

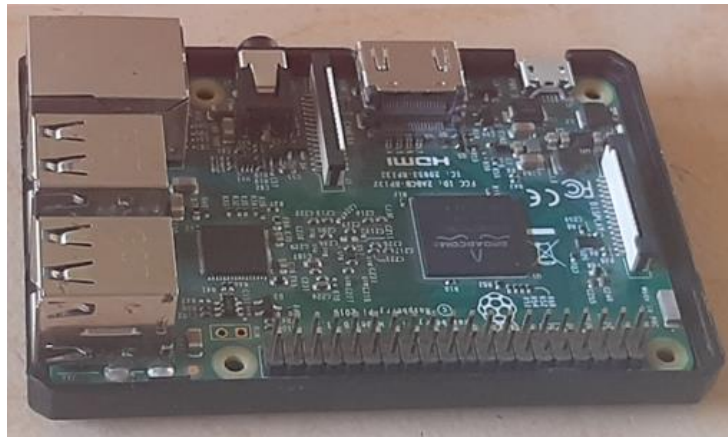
The choice of hardware plays a key role in the kind of robot designed (Gomez *et al.*, 2018). For this design Arduino Uno microcontroller was used for programming purposes since it is the most accessible and easy to use in programming. The hardware part of the robot was majorly designated to perform two tasks. The first task was robot movement which would be controlled by the Arduino Uno microcontroller. The second task was carried out by the Raspberry Pi microcomputer which added some video capabilities for purposes of improving the overall performance of the robot. The microcontroller helped in tracking the position of the robot camera. It also aided in decisions related to movement commands and communication with the microcontroller. The various components were assembled together whereas a plastic casing manufactured by 3D printing was used to cover the robot internal components.

In this study Arduino Uno was employed and is a microcontroller board based on the ATmega328. The Arduino Uno has 14 digital input/output pins (of which 6 can be used as PWM outputs), 6 analog inputs, a 16 MHz crystal oscillator, a USB connection, a power jack, an ICSP header, and a reset button.

The fabricated robot was powered by rechargeable Lithium ion batteries. The sensors and the motors were connected through electronic-circuit interfaces. The enhanced serial port integrated circuit was connected to the Arduino Uno microcontroller through the Transmit and Receive signals as a web server. The Arduino microcontroller and Raspberry Pi are shown in Figure 3.10 and 3.11 respectively.



**Figure 3.10: Arduino Uno Microcontroller**

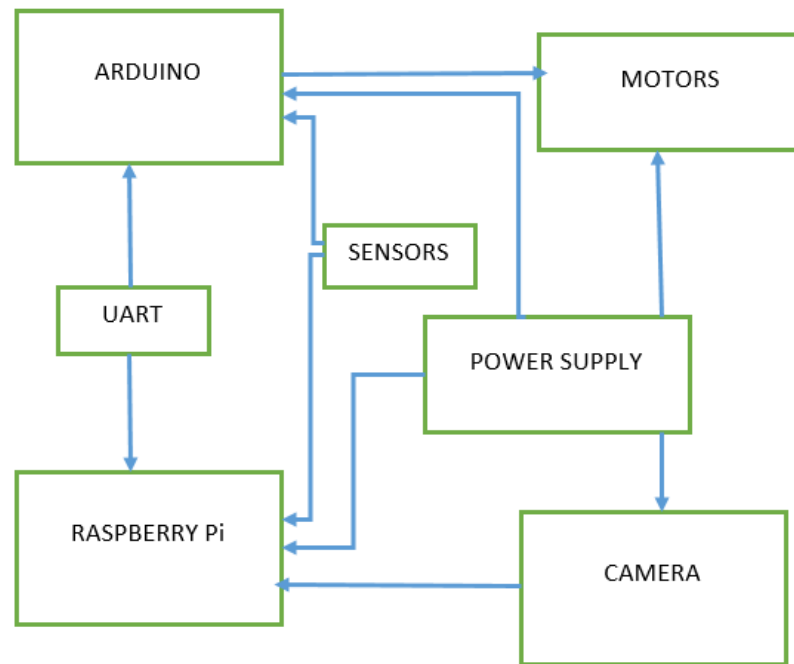


**Figure 3.11: Raspberry Pi**

The logic level converter circuit acted as an intermediate between the two integrated Circuits because of their different voltages use. The Arduino Uno microcontroller performed the following operations;

- i. Control of the dc and the servomotors
- ii. Controlling the action by the actuators
- iii. Interpretation of information received from the sensors which include infrared sensors and Ultrasonic sensors as per the programme.

The block diagram of showing connections of different components of the robot is shown in Figure 3.12.



**Figure 3.12: Block Diagram of the Robotic Car**

### **3.11.5 Robot Arm**

#### **Overview of a robot arm**

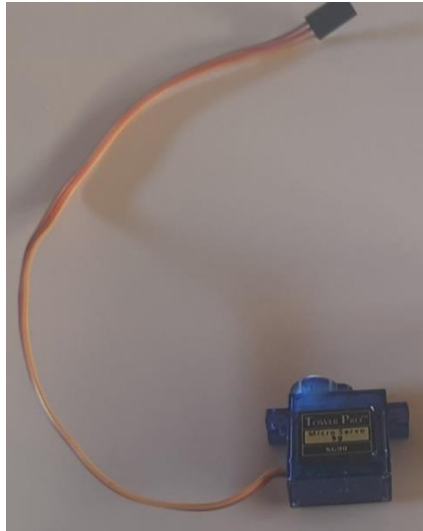
A robotic arm is a mechanical arm designed with several links and joints. It is programmed such that the various joints make motion that is rotational or translational (Serrezuela *et al.*, 2017). The robotic arm is designed using servo motors to facilitate the movement of various joints. A Microcontroller is used to control and coordinate the various motions by the servomotors. The end of the arm is fixed with a gripper which can pick a given object and place it at different location as guided by the programme.

#### **The robot arm hardware design**

A pick and place robotic arm was fabricated with a capability of carrying a maximum weight of 120 grams. In order to guarantee that the robotic arm design met the expectations of the researcher, the following design criteria were developed;

- i) **Ease of manufacturing and affordability:** The arm should be made from locally available materials (Takacs *et al.*, 2016). This would ease the manufacturing process of the arm and also lower cost of manufacturing thus making it affordable to secondary schools.
- ii) **Performance:** The arm should be designed in way that it can lift, move, lower and release an object in a manner similar to that of a human hand.
- iii) **Reliability:** The arm should consistently pick up and place objects in a smooth manner and in the expected location. The arm should not drop objects until to the designated position.

During the fabrication the servo motors were selected based on weight of the joints and as such they should be selected carefully. Additionally, plastic material was selected in the form the links and the base of the arm. The material was selected since it is strong, readily available and affordable in cost. The parts were printed by using a 3-D printer. Arduino Uno microcontroller was used for programming purposes. The robotic arm was designed to function in a similar manner to a human arm. It was designed with various links which are moved by joints allowing either rotational motion or translational displacement. A servomotor is a rotary actuator which allows control of angular position in a precise manner. It allows for accurate control of the links in a linear or angular position, acceleration, and velocity. It consists of a dc motor, gear reduction unit, position sensing device and a control unit. The servomotor was programmed to allow rotation required for just a certain angle. A servomotor used in this study is shown in Figure 3.13.



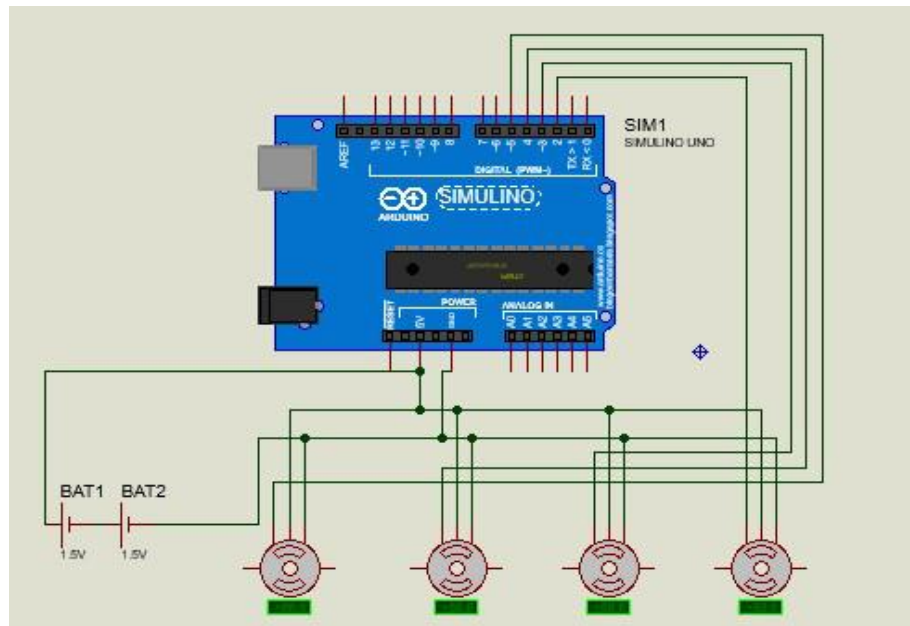
**Figure 3.13: Servomotor**

The servo-motor used in this study had the following specifications:

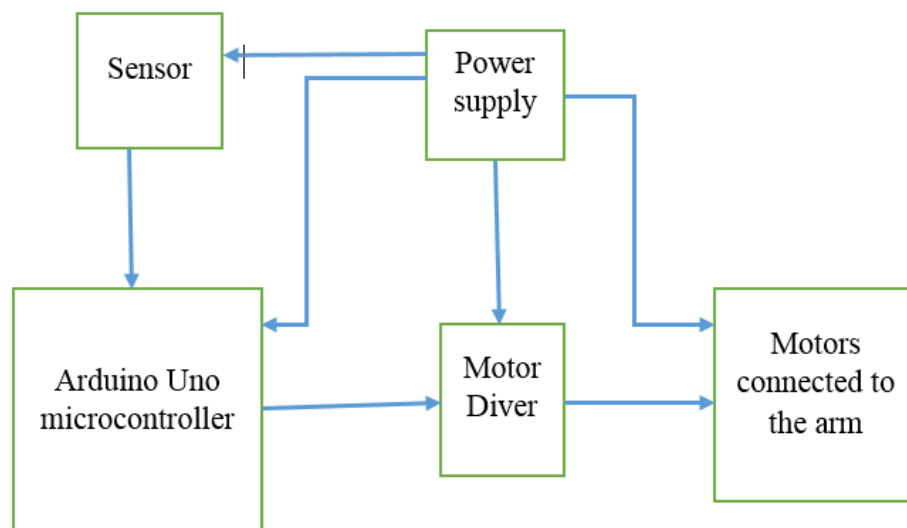
- Operating Speed (4.8V no load): 0.11sec/60 degrees
- Operating Speed (6.0V no load): 0.10sec/60 degrees
- Stall torque: 2.2kg/cm(4.8V);2.5kg/cm(6.0V)
- Operating Voltage: 4.8-6.0V
- Temperature Range: -30<sup>0</sup>C~60<sup>0</sup>C
- Item size: 3.3 X 3.2 X1.2cm
- Item weight: 13g
- Connector wire length: 24.5cm

In this fabrication four servomotors were employed. They were programmed to produce motion with various degrees and also to facilitate linear motion. The first motor was attached to the bases and would move the entire arm at 90<sup>0</sup>. The second motor was attached to the first link and would move the second part upwards at about 60<sup>0</sup>. The third servomotor was programmed to move the link attached to the gripper at about 30<sup>0</sup>. The fourth motor is used for purposes of gripping an object and also

releasing it at the desired position. The wiring diagram is illustrated in Figure 3.14 while the block diagram for the robotic arm is shown in Figure 3.15. The arm was fabricated using 4 servomotors and an application of 4 degree of freedom was chosen. It was designed to pick a load at a particular point and drop it at another point.

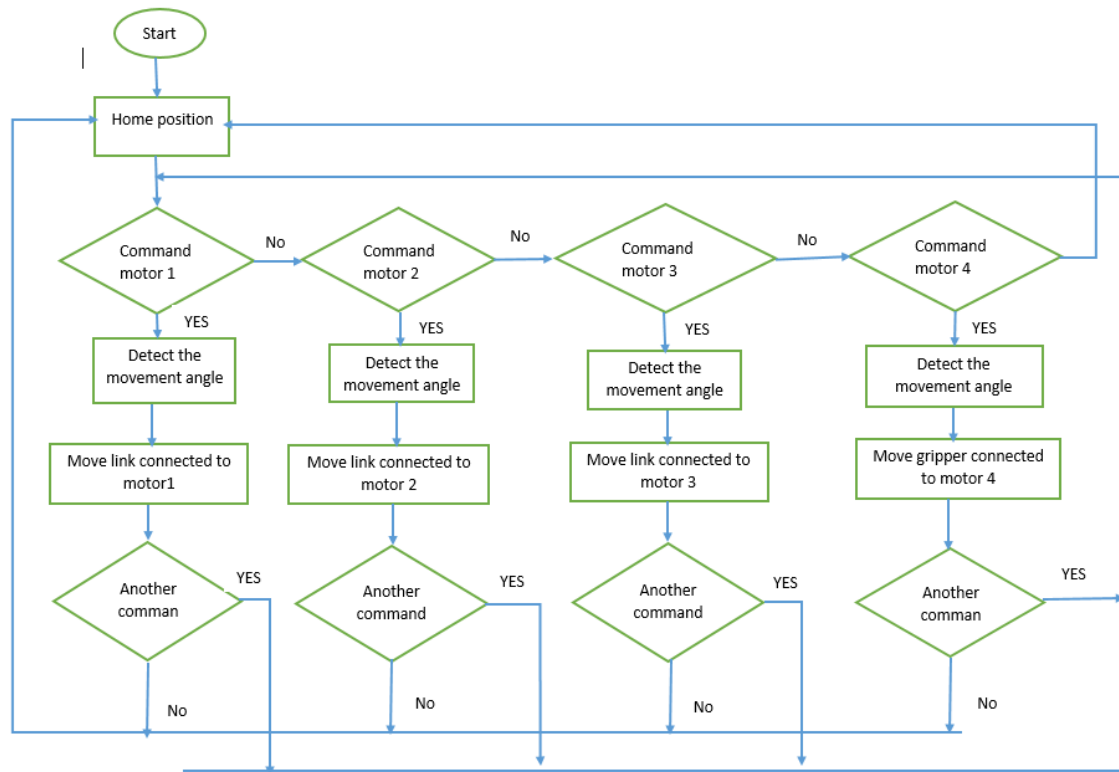


**Figure 3.14: Wiring Diagram for Robot Arm**



**Figure 3.15: Block Diagram for the Robotic Arm Design**

The flow chart for the operation of the robotic arm is shown in Figure 3.16. The programme for the robotic arm is shown in Appendix H.



**Figure 3.16: Flow Chart for the Robotic Arm Operation**

The robot arm was fabricated with four servomotors. The servomotors were labelled 1 to 4 where a programme was developed to allow movement of the servomotors at different degrees to enhance picking of an object and placing it in another location. The four servomotors are programmed so that motor 1 is connected to the base and moves the entire arm. The second and the third motors move the links connected to them while the fourth motor is connected to the gripper in order to allow gripping and release of the object.

### 3.11.6 Software adopted for the educational robots.

The fabricated and implemented robot in this research were line-following robot design, obstacle avoidance design and robotic arm. The software implementation of

the robots included reading sensor data, storing the data and driving the actuators. This was achieved by programming the Arduino Uno microcontroller where the software would periodically poll the microcontroller input port to detect a line or an obstacle for the line follower and the obstacle avoidance robot. The Arduino microcontroller is programmed for the robot arm in order to coordinate the angular movement by the four servomotors to facilitate picking and placing of objects. When it senses a line or an obstacle it will actuate the motors connected to it to either stop, reverse or change direction. Infra-red sensors were connected underneath the robot in order to detect the line and act accordingly as per the programme. An Ultrasonic sensor was placed on top of the robot car design in order to detect obstacles. The microcontroller is programmed such that it interprets the distances calculated and initiates an action by the motors so that the robots may avoid obstacles.

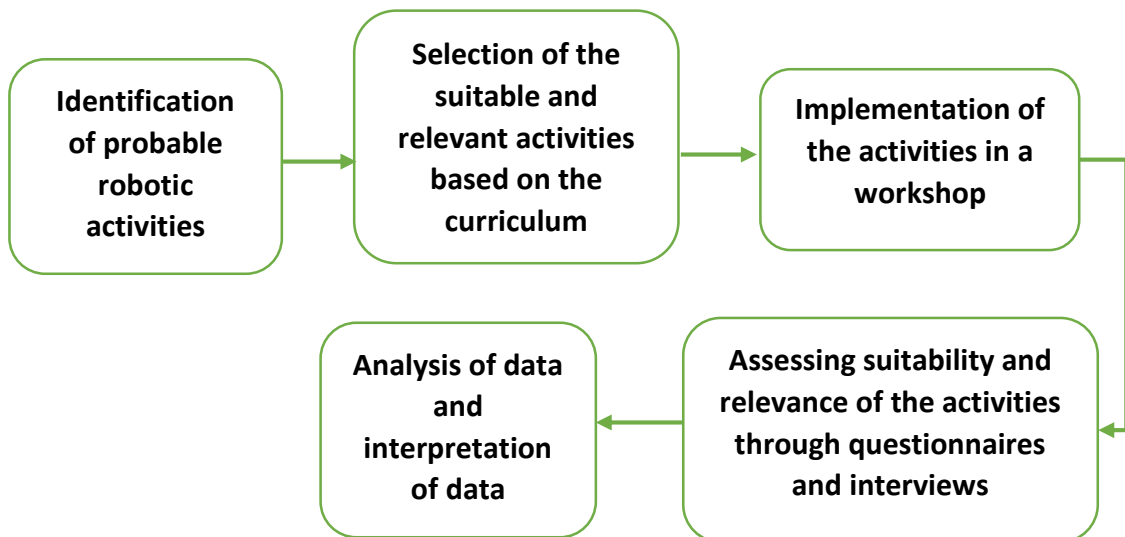
### **3.12 The procedure and implementation of the developed Robotic Activities**

Robotic activities were developed based majorly on the two main robot designs of the robotic kit. The robots fabricated by the researcher were used for the development of the activities after which the selection of the most suitable and relevant activities were selected for a workshop. A workshop was then organized where Form 2 students and Physics and Mathematics teachers were taken through the activities. The suitability and relevance of the activities were assessed through the questionnaires administered to the students and interview conducted to the Physics and Mathematics teachers. Data obtained from both teachers and students was then analyzed.



### 3.12.1 Development of the robotic activities

The block diagram showing the process of the development of the robotic activities is shown in Figure 3.17.



**Figure 3.17: Block Diagram on Development of Educational Robotic Activities**

The activities included simple programming, building electrical circuits, various measurements exercises, basic electronics, basic 3D drawing, robot assembly, sensors and their applications, basic programming of the robot parts like sensors and motors, basic mechanics, motors and gears applications. Alimisis (2013) noted that constructivism and constructionism, curriculum and the learning environment, are some of the key elements that can promote innovation in robotics.

In this study, a 4-Step Active Learning Cycle (ALC) model, a modification of the 5-step ALC by iTEC as outlined in Saygin *et al.*, (2012) was adopted to develop activities and expose form 2 students to Engineering in a progressive way. Graven, and Samuelsen, (2011) supported the development of robotic activities through active learning model. The use of the model accorging to them helps learners remain active in the learning process since the activities are engaging. It leads to growth in creativity

and develops learners interest towards Engineering and contributes to making the learning environment active by improving learner participation in classes. According to Saygin *et al.*, (2012), the Active Learning Cycle model facilitates project-based learning, which makes learning exciting and applicable to real-life problems. The model engages learners making them active in the learning process and presents science and Engineering concepts in clear, appropriate and real-world contexts. These findings from the researchers informed my choice of the ALC model in the development of the activities. The four steps of the development included concepts, models, applications, and problems.

**i. *Content***

Activities were developed such that core concepts that learners want to learn are at the Centre of every session. The activities were then split into simple tasks which relate to the various concepts. In this case, a concept or a set of related concepts to be covered in a lesson are identified, an activity is developed and then tasks regarding to the concepts are set. The main objective of this step was for the students to have an operational understanding of the concept.

**ii. *Demonstration***

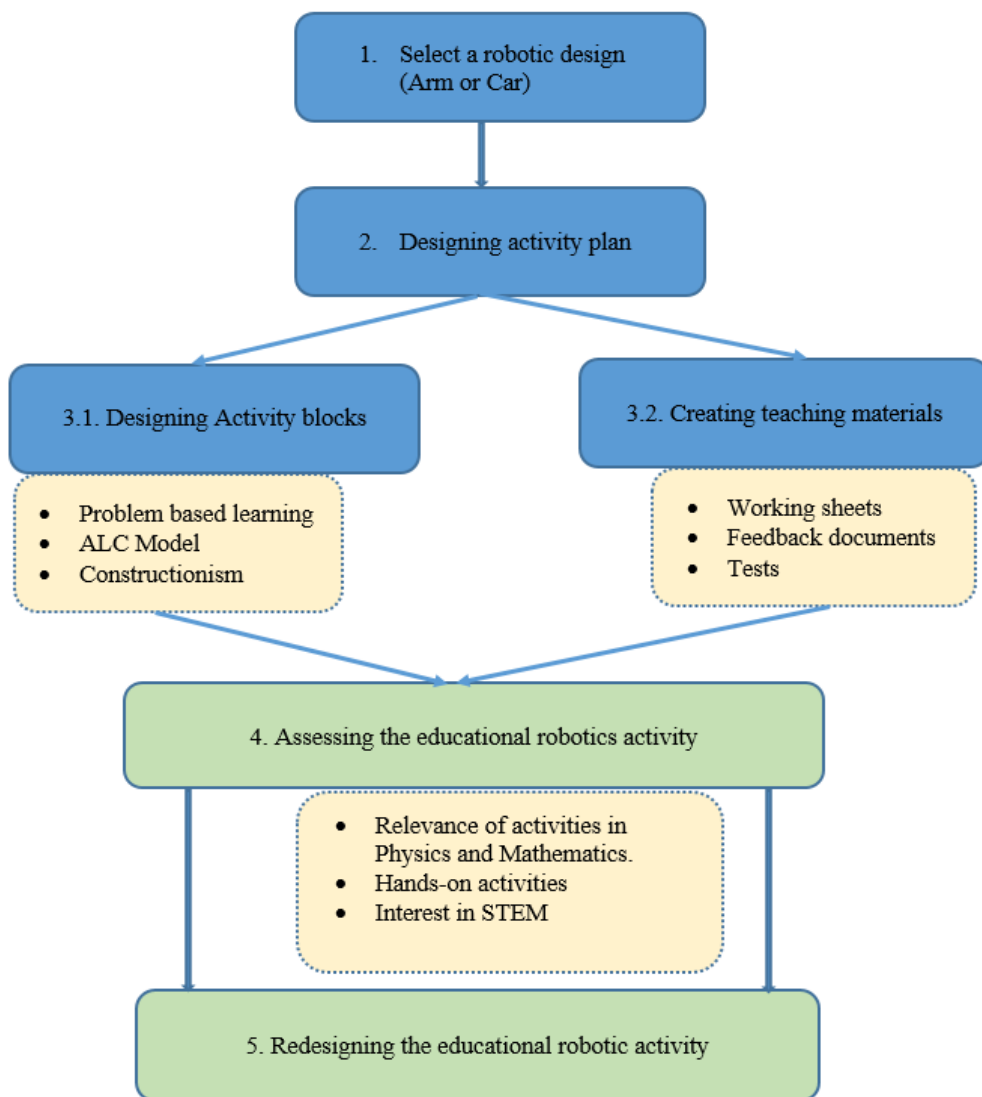
Activities were developed to illustrate the concepts and design challenges. The activities developed demonstrated what the robots were supposed to do. The tasks derived from the activities were used to demonstrate various concepts.

**iii. *Application***

The activities were developed to bring on board the hands-on component part of the lesson. Such applications performed inform of tasks by the students allow them to explore and interact with the concepts.

**iv. Problem**

The activities were designed for the students to continue demonstrating understanding through solving an open-ended problem involving the concepts to contend with the complex and ambiguous ideas of real-world situations. In this study, the developed activities were based on a robotic car and robotic arm. The steps followed in the development of the robotic activities are illustrated in Figure 3.18.



**Figure 3.18: Steps in Developing Educational Robotic Activities**

The educational robotics activities were developed in a systematic process. Figure 3.18 shows a guideline with five steps followed. The first step is selection of the robot design, either the robotic car or robotic arm. This is followed by the development of educational robotics activities carried out with an activity plan. The activity plan included activity blocks using a constructionism approach, a teaching strategy based on problem-based- learning, and a standardized structure with the ALC model. At the same time, the teaching materials were developed. The other step included assessment of the educational robotics activities in relation to the interest they create in Physics and Mathematics. The last step includes the use assessment results to carry out the redesigning of the educational robotic activities.

The robotic activities developed included:

- i. Basic Technical drawing activities to design basic shapes in preparation of 3D printing.
- ii. 3D printing activities to print robot parts.
- iii. Basic electronics activities including measurement of electrical components.
- iv. Activities involving identification of robot parts.
- v. Basic robot parts programming.
- vi. Line following robot activities.
- vii. Obstacle avoidance robot activities.
- viii. Robotic arm rotational dynamics activities.

### **3.12.2 The implementation of the Robotics Activities Based on the Active Model**

In this research, a 3-day workshop for teachers and form 2 students was organized. The activities were built based on our fabricated robots. In this workshop, Engineering

design concepts were introduced along with hands-on applications using our robot design. The workshop activities were implemented around the ALC model: During the workshop, presentations and discussions on robot designs and activities based on the robot developed were made. The workshop's aim was to achieve the following objectives:

- i. To demonstrate the Science principles through a robotics application using robot designs.
- ii. To guide learners through hands-on practices for effective learning.

The expected outcomes of the workshop were that:

- i. Participants would be able to define the main components of the robotic car and robotic arm.
- ii. Demonstration of how different components of the robotic car and robotic arm can be programmed.
- iii. Application the robotic arm and robot car activities to Science principles.

The workshop schedule was planned as follows.

### **Day 1- Introduction to robotics**

8.30-9.00am	Registration and filling of questionnaires
9:00-11:00 am	Introduction to robots, components
11:00-13:00 am	Electricity and green energy
14:00-16:00 am	Robot parts manufacture (CAD)

### **Day 2-Robotic activities and Integration of activities to Mathematics education**

8.30:9:00	Registration and recap
9:00-11:00	Robotic activities (Programming parts of a robot)
11:30-13:30	Robotic activities (Mathematics)
13:30-16:30	Robotic activities (Mathematics)

### **DAY 3 - Robotic activities and Integration of activities to Physics education**

8:00-8:30 am	Registration and recap
9:00-11:00	Robotic activities (Physics)
11:30-13:30	Robotic activities (Physics)
13:30-16:30	Robotic activities (competition)
4:00-4:30	Workshop Evaluation and questionnaires.

The workshop evaluation included tests, questionnaires for the students and interviews for the teachers. The form 2 students were also taken through solar energy which they were to use in powering the robotic car. The sessions were conducted at Murang'a University of Technology. Each day's topics and challenges were developed in form of activities. The various Physics and Mathematics topics were taught through hands-on tasks derived from the general activities.

#### ***i. Content***

Content was delivered using a variety of approaches. The major approach was demonstration. The purpose was to give students the basic foundational information they needed before they could start interacting with the activities.

#### ***ii. Demonstration***

The robot designs were used to illustrate the robotics concepts and design tasks related to Physics and Mathematics topics. The instructors who consisted of the researcher and two assistants demonstrated what the robots were supposed to do. This included the general activities such as a robot following a line, avoiding obstacles and picking up an object and placing it in a given position.

#### ***iii. Applications***

Once the students understood the basic concepts and having interacted with the robot designs with various activities developed them, students applied their knowledge

through programming robot parts. They also applied their knowledge in solving various Physics and Mathematics problems presented to them in form of tasks. The tasks that formed this activity were the most hands-on as students were working with the robotics kits and the programming software. They would also perform tasks in groups with each student performing a specific task. At this time, students were only working within their groups and there was no competition element yet.

#### *iv. Problem Solving*

In the previous steps students were guided entirely by the instructor in the tasks they were performing. The students would be guided on the various requirements on various activities for instance what sensors to use for various activities. However, in this step students were given tasks which were not guided and it was left to them to solve the various problems.

Based on the developed robotic activities, it can be said that an active learning model was adopted. From the developed robotic activities, it can be depicted that understanding of concepts is enhanced by having a mental model that reflects the structure of the concept and its relationship to other concepts. Therefore, presenting organized knowledge through concepts that are combined to form propositions that show the relationship among concepts is essential. (Graven and Samuelsen, 2011). It was also evident that learning is an active and continual process, where knowledge is constructed, continually updated, and refined as the individual gains more experiences.

During knowledge construction and refinement, individuals use all their senses: Interacting with a physical object or an experiment enhances and promotes learning. Effective learning in sciences involves engaging students to be active learners; presenting Engineering concepts in concrete, relevant, and real-world contexts; and

immersing students in authentic Engineering-based activities (Graven and Samuelsen, 2011).

The different activities developed agreed with Jung and Won (2018) who stated that different activities ranging from design, programming, application or experimentation with robots can be developed. From the development of the activities, it was evident that the participants were introduced to robotics, their functioning and components and guided on how they can be used in teaching concepts in Physics and Mathematics. This helped them understand on their functionality and how they could be manipulated to perform different tasks. According to Screpanti *et al.*, (2018), educational robotic activities developed such as design, programming and experimentation with the robots should help the users familiarize on the functionality of robots.

The development of the robotic activities involved a 3-day workshop that was divided into different tasks such as introduction of the components and application of the robotic car and robotic arm in performing tasks related to Mathematics and Physics. This followed Chen and Chang (2018) recommendation that robotic activities development should be divided into tasks requiring different skills and concepts thus helping participants fully understand how the robot works.

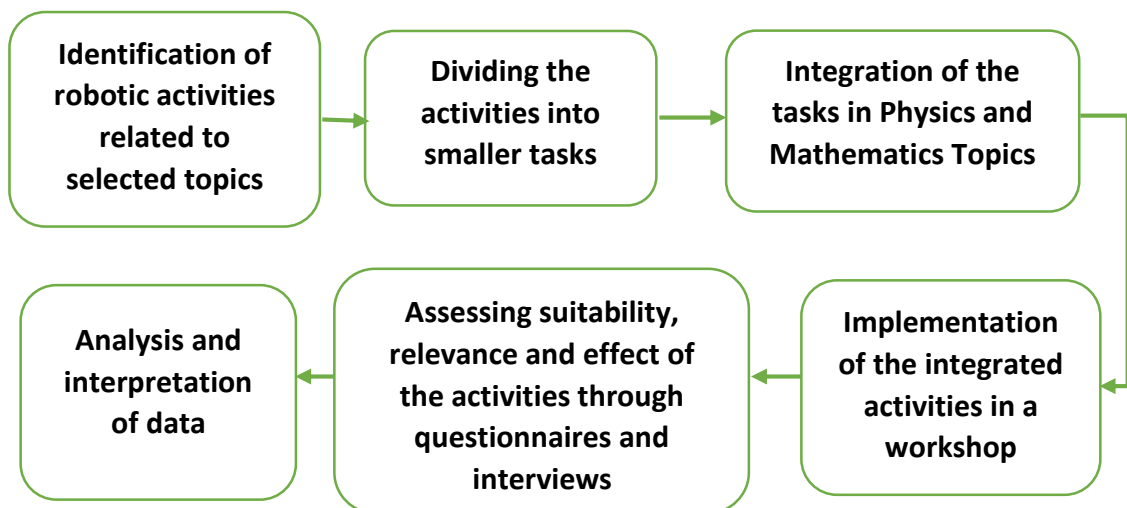
By adopting an active learning model, constructionism was emphasized where the learners were encouraged to understand how the robotic car and robotic arm were created and how they functioned. This meant that they would easily experiment with the robotic car and robotic arm making their application to be learner centered. This approach concurred with Scaradozzi *et al.*, (2020) who indicated that development of robotic activities should be learner centered which encouraged participants in any



robotic experiment to Think, Make and Improve. As a result, learners can easily experiment with the robots and therefore solve challenges that are real-life based.

Researchers have done investigation on the implementation of integrated STEM lessons within courses that have a single subject science focus. Ntengwa and Oliver (2018) examined and generated an account of the implementation processes. In their study qualitative data was collected from interviews. The researcher adopted both quantitative and qualitative methods of data collection in the integration of the robotic activities to Physics and Mathematics. In this study the data on the effect of the integrated activities obtained through questionnaires administered before and after exposure to the students and interviews of the teachers.

The block diagram on the process of integration of the robotic activities is shown in Figure 3.19.



**Figure 3.19: Block chain Diagram on Integration of the Educational Robotic Activities**

In this research, robotic activities developed from the robotic car and robotic arm designs, were integrated in the subjects' students learn in class. The main focus of the robotic activities was to relate the robotics with Physics and Mathematics. The integration included selected topics in Physics like electricity, linear motion, measurements and basic electronics. The emphasis on the practical aspects included building electrical circuits, simple programming and measurement of speed and distance after the movement of the robot. Additionally, the educational robotic activities developed were applied in teaching some concepts like kinematics and dynamics which were studied through the movement and interaction of the robot arm with the environment.

The other set concept that were learnt are in modern Physics like the photoelectric effect that governs the operation of the light sensors (phototransistors) which were easier to explain and provided an avenue of describing the propagation of electromagnetic waves. The ultrasonic sensors used and programmed in the robot, similarly allowed the students to learn about the dispersion of sound waves. The activities were also integrated in topics such as forces, Linear and circular motion. In Mathematics the educational robots were integrated in topics like geometry, Linear motion, Trigonometry, Area and Perimeter among others. The integration was done to facilitate the link between theory and practice in Physics and Mathematics. For purposes of integration the activities included:

- i. Physical demonstrations of experiments with simple low cost materials, providing learners the proof of the theory learnt in class;
- ii. Games and competitions that promote learners' curiosity and interest in the subjects.

- iii. Selection of themes to be developed by means of workshops

After this consideration, a workshop on Educational Robotics was conducted, which included developing robots and programming different parts of robotic arm and car.

The activities developed and the subjects integrated is shown in Table 3.3 while the manual used to conduct the activities is found in Appendix F

**Table 3.3: Integration of Robotic Activities in Physics and Mathematics**

<b>Developed Activity</b>	<b>Topic Integrated</b>	<b>Subject</b>
Basic Technical drawing activities	Geometry, Area and perimeter of Shapes	Mathematics
Basic electronics activities	Measurements of values of components, basic electricity	Physics
Robot part identification and assembly	Sensors and transducers, work and energy	Physics
Basic robot parts programming.	Programming	Technology
Line following robot activities.	Reflection of light, Linear motion, Speed, Acceleration	Physics and Mathematics
Obstacle avoidance robot activities.	Waves, Reflection and distance Calculation	Physics and Mathematics
Robotic arm rotational dynamics activities.	Geometry, Angles, Circular motion Rotation, Translation, Forces and Energy	Physics and Mathematics

### **3.13 Integrated robotic activities in Physics and Mathematics education.**

In order to establish the effect of integrating the robotic activities, the learners filled a questionnaire with items assessing the effect of the robots in understanding, creativity

and interest. The questionnaire was administered before and after exposure to the educational robot.

In the first session the learners were taken through basic programming of the robots, using the designed robotic car. They moved the car forward and backwards in linear motion at constant speed, acceleration or deceleration. The students learnt to program their robot to move forward and backward in linear motion using the Arduino Uno programming environment. In the 2nd session, the main focus was Physics where the students were reminded the basics of motion at constant speed and were asked to program their robot to move forward and then backward at constant speed. They were instructed to assemble an ultrasonic sensor on their robot in order to detect the distance from a stable object. They also assembled and programmed infra-red sensors on the robotic car in order to detect a black pathways drawn on some wooden boards. In this session, the students were also reminded on the concept of acceleration, deceleration, circumference and perimeter of particular shape. In the 3<sup>rd</sup> session Mathematics activities took the Centre stage. The students were guided on the process of assembling the robotic arm. The arm was used to illustrate various concepts in Mathematics. These include; Geometry, Angles, Circular motion, Rotation, Translation, Forces and Energy among others.

### **3.14 Procedure of assessing the impact of the Robotic activities**

The impact of the educational robots was assessed using three approaches: questionnaire items, tests and a follow-up. The questionnaire items on impact assessed the choice of subjects' combination towards an Engineering career pathways. The questionnaire was issued before exposure and after exposure to the educational robots and differences in the responses on items pointing towards the students' career choice

assessed. The learners were also given three tests; a pre-test before exposure to the educational robot, first post-test after being exposed to the educational robot issued at the end of the second week and a second post-test after being exposed to the educational robot issued at the end of the third week. A follow-up was made 6 months after being exposed to the educational robot. This was necessary to validate whether the responses in the questionnaires regarding career choices were based on excitement due to exposure to the educational robot or not. The follow-up made evaluated whether the students actually selected subject combinations that aligned with those that they had indicated on the questionnaires.

### **3.15 Data Analysis Procedures**

In this study, quantitative and qualitative data was obtained.

#### **3.15.1 Analysis of Qualitative Data**

In this study, a structured procedure was used in analyzing the qualitative data. The first objective sought to fabricate robot arm and car and assess the suitability of the robots developed. The second objective sought to examine the relevance of the robotic activities developed to form 2 learners. The two objectives were analyzed qualitatively where the Secondary School Physics and Mathematics teachers were interviewed and gave various responses which were then reported. Themes were identified from the interview responses after which reporting was done through prose as per the study's objectives. In this study, the narratives from those interviewed were transcribed and presented word for word from the respondents in order to capture actual responses by the teachers on the various aspects ranging from the robot design, development and integration of the robotic activities. This approach was particularly useful as it allowed

varied experiences from respondents to be presented as primary raw data (Roulston & Choi,2018.).

The coding schemes used in this study made the analysis more systematic. The aim of the qualitative data analysis was to reinforce the findings from the quantitative data (Firmin *et al.*, 2017).

### **3.15.2 Analysis of Quantitative Data**

Data collected from the form 2 students was sorted out to identify any incomplete or inaccurate responses. The data was then coded by assigning different data sets with simple numbers to help in data analysis. This allowed for reduction of large quantities of information into a form that was handled more easily during data entry. The researcher analyzed quantitative data using descriptive statistics where mean, standard deviation and percentages were computed as required. Inferential statistics was employed in making inferences and predictions about the population, based on the sample results obtained.

The third and the fourth objectives included examination of the effect of integration of the robotic activities to the learners' perception of Physics and Mathematics and assessment of the impact robotic activities to the form 2 students' interest to Engineering career. These employed the data collected quantitatively from an analysis of the responses by the students on a Student Choice of Engineering Career Pathways Questionnaire (SCECPQ). Quantitative data as obtained from the questionnaires was cleaned, coded and then entered into SPSS version 25.0 for analysis. Quantitative data was analyzed using descriptive statistics and inferential statistics. In this study, descriptive statistics involved the use of frequencies, percentages, mean and standard deviation. Inferential statistics comprised the use of Paired sample t-test, sign test,

correlation analysis, one-way ANOVA, Chi-Square test. The significance level was set at 0.05.

### **3.16 Ethical Issues**

According to Artal and Rubenfeld (2017), research should be conducted in such a way that it does not endanger the future research. The researcher utilized various ethical considerations in the entire research period. He sought permission from various institutions which included: The University, National Commission for Science, Technology and Innovation (NACOSTI) and principals of the selected public secondary schools to conduct the study. The letter of permission to conduct research by Murang'a University of Technology attached in Appendix M while the research permit by NACOSTI is attached in Appendix N. The researcher also sought informed consent from the respondents before the issuance of the questionnaires and conduction of the interview (see Appendix B).

The researcher took the respondents through the aims and goals of carrying out the research since it was their right to know. The secondary school principals were contacted through the administrative team set up by the Royal Engineering Academy. The parents whose children were selected to participate in the research were issued with the informed consent letters. Only those students' whose parents consented were given the questionnaires to fill. The researcher explained to the respondents that they were not required to indicate their names in the questionnaires. This ensured that confidentiality was adhered to and that no victimization was allowed. This reassurance was printed in the introduction to the questionnaire so that all the respondents were aware of it.

The study instruments were stored in a safe lockable place during and after data analysis. The researcher also tried to maintain the highest level of objectivity in discussion and analysis of the results throughout the research. All sources of information consulted were cited appropriately inside the text and acknowledged in the reference list as guided by American Psychological Association (APA) referencing system.

### **3.17 Summary**

This study design employed in this research is quasi-experimental design. A sample of 270 Form 2 students was considered. The students were exposed to robots and robotic activities through workshops. The study employed active learning model in the exposure of the students to the robotic activities during the workshops. In order to study the impact of robotics activities on the students' interest in Engineering career pathways, the students were issued with tests, pre and post questionnaires. Quantitative data was obtained from the tests and the questionnaires. This was then followed by data analysis. Physics and Mathematics teachers from the schools where the learners were selected also participated in the workshops and were also interviewed as key informants. The qualitative data obtained from the key informants was also analyzed based on various themes. The researcher utilized various ethical considerations in the entire research period.



## CHAPTER 4

### RESULTS AND DISCUSSION

#### 4.1 Introduction

This chapter provides results of the study. The findings are interpreted and discussed according to published literature on the subject. The main objective of this study was to investigate the impact of the educational robotic activities on secondary school learners' decision towards selection of an Engineering Career.

Robotic car and arm were Fabricated, robotic activities developed and integrated to Physics and Mathematics. Prior to introducing the robot to the students, students were presented with a pretest questionnaire which they were required to fill on items regarding integration of educational robots on their interest to pursuing an Engineering career pathways. An educational robot was then assigned to the learners where they were exposed to robotic activities developed after which a posttest questionnaire similar to the one utilized in the pretest study was administered.

The students were assigned random numbers which they were supposed to fill in the pretest and posttest questionnaires. This helped in identifying corresponding pretest and posttest questionnaires for each student who participated in the study. Data collected was cleaned to ensure that only questionnaires that were correctly filled, both for the pretest and posttest, were used in the data analysis in this study. Only those corresponding questionnaires that were correctly filled were used in the final analysis.

#### 4.2 Qualitative data findings

The first and the second objectives were achieved after fabrication, development and integration of robotic activities for purposes of STEM education. After the fabrication

of the robots, the key informants' opinions were analyzed qualitatively on the suitability of the robots. Similar opinions were obtained and analyzed qualitatively on the development and integration of robotic activities. The findings are discussed in section 4.3 and 4.4 respectively.

### **4.3 Fabrication of an Educational Robotic car and arm**

The structure of the robot was constructed using recycled plastic sheet materials, with optimal measurements, 150 mm diameter, 15mm height and maximum weight of 400 g, so as to minimize materials' usage. The fabrication also included use of readily available circuits for the infrared and ultrasonic sensors, simple and easy to install motors and which would rotate in either direction. The car had medium sized wheels and a caster wheel attached at the front for easier and smooth movement with optimal energy consumption. For this study's robotic design, Arduino Uno programming was adopted due to its accessibility and ease of use. Additionally, a Raspberry pi microcomputer added some video capabilities.

The design for the overall shape of the educational robot was through researcher's own conceptualization and did not involve designing experts. The fabricated robots were simple and without complex features. The fabricated robots were assembled in such a way that the learners would see the various components functioning. The robots were cheaper unlike the ready-made robots which are not affordable to many public secondary schools. Additionally, the printing of the 3-D chassis was done in the locally available 3-D printers. This further contributed to optimization of resources at the construction stage resulting to low cost robots.

#### **4.3.1 Testing of the fabricated robots**

The robotic car was fabricated with the line following and obstacle avoidance

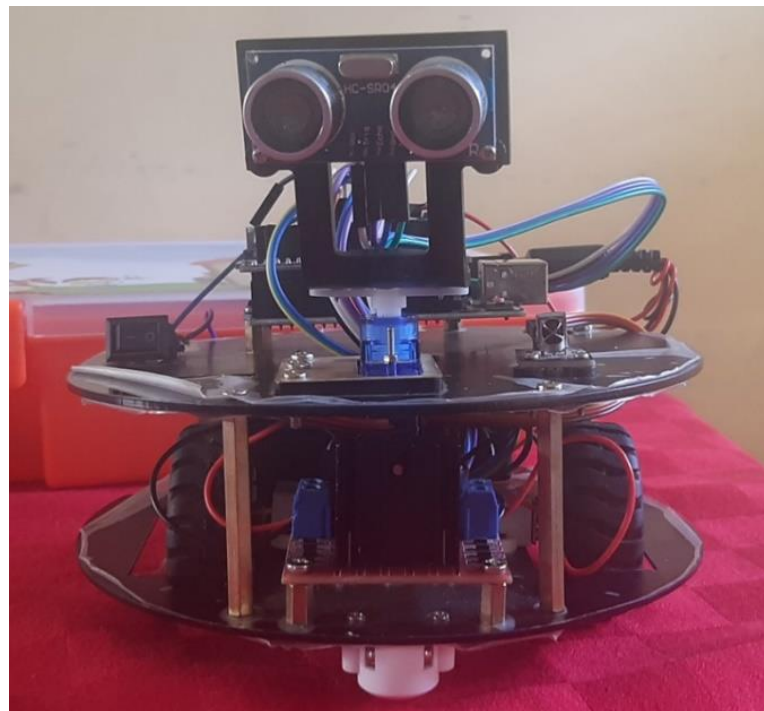
functions. The line following function was realized through infra-red sensors. The robotic car followed a straight black line and a black curved line as expected. The robot car was light in weight with high speed motors and high sensibility sensor circuit. The weight of the designed robot was about 350grams. The robot car made use of two wheels` in rear and a caster wheel on the front so that the robot can move with ease. It was fitted with three IR sensors one on the left, one in the middle and one on the right. The middle sensor detected the black line and therefore the robot moved only on a black line and stops when the pathways comes to an end. When the robot deviated from the black line, the left or the right sensor would detect and send the signal to the microcontroller. A correction signal would be sent to the motors so that they could turn to the correct direction and align the middle sensor to the black line. The Microcontroller Arduino UNO and Motor Driver L293D were used to control direction and speed of the motors.

The obstacle avoidance function was realized through the Ultrasonic sensor. It was Arduino-controlled and would move around detecting obstacles in its way and avoiding them as programmed. As the robot car moved, the ultrasonic sensor would send an ultrasound wave to the front position (90 degrees), right position (36 degrees), and left position (144 degrees).

The final hardware was tested on the obstacle avoidance capability which revealed the limitations of the detection algorithm. The limitations were related to cases of some obstacles not being detected and this was as a result of the sensor not being able to measure obstacles outside the measuring range of the sensor. When an object is in the way of the car and this object is not within the line of sight of the sensor, it will not be detected thereby leading to collision. To avoid this, the testing was further carried out

in an enclosed area where the wall is the only obstacle and the car was able to move freely without collision.

The robotic arm functioned as expected in that it met three set conditions by the researcher. The arm was easily manufactured from locally available materials and a locally assembled printer making it affordable. The arm also performed the planned tasks as expected in that it picked an object from a given point and placed in a designated point. The robot arm also met reliability test in that it could consistently pick up and place objects in a smooth manner and in the expected location. The arm did not drop objects on the way but delivered an object to the designated position. It could carry an object whose weight did not exceed 140g. The fabricated robotic car and robotic arm are shown in Figure 4.1 and 4.2 respectively.



**Figure 4.1: The fabricated robotic Car**



**Figure 4.2: The Fabricated Robotic Arm**

#### **4.3.2 Bill of Materials**

A low-cost robotic car and a robotic arm were fabricated. The estimated cost for the educational robotic car was Ksh. 8, 500 while that of the robotic arm was Ksh. 6, 500; thus an estimated total cost of Ksh. 15, 000 (see Table 4.1).

**Table 4.1: Estimated Cost of the Educational Robot**

<b>Robot car Approximate cost</b>	
Item	Total cost in ksh
3 D printing of the robot car chassis, cover and Battery holders	2500
Arduino Uno	1800
Dc Motor(4X300)	1200
Wheels (4X200)	800
Castor wheel	150
Ultrasonic sensor	200
Infrared sensor(3X200)	600
Batteries (pair)	550
Connectors and glue stick	400
Bolts and nuts	300
<b>Total</b>	<b>8500</b>
<b>Robotic arm approximate cost</b>	
3 D printing of the links to the arm	1500
Servomotors(4X400)	1600
Breadboard	300
Arduino Uno	1800
Batteries	550
Jumper wires and other accessories	450
Bolts and nuts	300
<b>Total</b>	<b>6500</b>
<b>Total cost of the robot designs</b>	<b>15,000</b>

In comparison with other ready-made educational robots, the cost of the fabricated educational robot robots was lower. The fabricated robots are estimated to cost total of 135 US dollars including inconvenience costs, with the next cheapest robot design being the Dash Robot selling at 155 US dollars. The cost of shipping the robots is not included in the estimated cost (see Table 4.2).

**Table 4.2: Costs Comparisons for Robots used for Educational Purposes**

Robot type	Estimated cost in USD	Source
Researcher's design	135	Researcher
Lego Mindstorms	460	Amazon.com
Dash robot	165	Amazon.com
WeDo robot kit	520	Amazon.com
Matalab Pro set robots	350	Amazon.com

### 4.3.3 Key informant Opinions over the Suitability of the Robots

In order to assess the suitability of the robots fabricated for purposes of developing of educational activities, the researcher formed the basis of seeking opinion from the key informants in regard to the suitability of the robot designs. To unravel this, the guiding question was, “What is your opinion on the suitability of the robotic designs (Car and arm) used in this workshop for developing teaching and learning activities in Physics and Mathematics?” It is worth noting that all teachers agreed that the robotic designs were suitable for developing activities for teaching and learning of Physics and Mathematics. They however gave various reasons on their opinions. Some of the respondents noted that the designs are suitable in that they are simple and flexible.

*“The designs are simple for the learners to understand and utilize in classroom set up. The designs show the practical parts of the robots functioning. The robotic cars are flexible in that they can move along the line in either direction” (TPM 01, 2021)*

*“The designs are suitable for the secondary school level. They in line with the various topics learnt in form 2 and other levels. They can be used in preparation of learning activities like rotation for the arm and effects of a force in the car design” (TPM 05, 2021)*

*“The movement of the robotic arm is like that of the human hand. The arm is flexible and picked and placed small objects. The arm can be used to teach learners the concepts of movement in the 3D space. In my own opinion the design is so captivating and therefore suitable for application in education” (TPM 06, 2021)*

*“The robot design and the activities thereof are interesting and motivating. The activities related to the robot designs can be done by the learners on their own with*

*little or no teacher involvement. This due to the simplicity of the designs and as such if activities developed around these robots are integrated into Physics and Mathematics, they would make the subject more appealing to the learners hence improving their interest” (TPM 09, 2021)*

Other respondents noted that the designs are suitable in that they are user friendly and affordable.

*“The robot car and arm designs are affordable even by day schools as compared to the LEGO Mindstorms which is more expensive and not affordable to many schools. The activities developed from the designs can make teaching and learning processes easier” (TPM 03, 2021)*

*“The designs are very appropriate in that the learners can easily interact with them without much supervision. All schools can afford the designs in that their cost is affordable to all even through the materials used to design them” (TPM 04, 2021)*

*“In my own observation the designs are made from locally available materials. This makes the robots cheaper than the internationally purchased robots. Due to this fact I would say that the robot designs are suitable for use by secondary school learners” (TPM 07, 2021)*

The design followed Vandeveld *et al.*, (2016) who stated that while designing an educational robot, the software and electronics aspects should be simplified. Additionally, educational kits should adopt readily available materials in order to construct robots that are of low-cost and ones that learners can construct themselves. The designed robot was highly mobile, in both clockwise and anticlockwise direction, implying that it could be adopted for a variety of user activities. This followed



guidelines by Chomyim *et al.*, (2015) who designed mobile robot kits for utilization in education and research using modular systems. The kits being flexible helped students in integrating them to various disciplines or topics in Physics and Mathematics quickly and easily while doing away with the need for complex modifications through unsafe tasks such as soldering. The highly mobility ensured that the educational robots would enable learners' creativity, thus enhancing adoption in a wide variety of disciplines.

The adoption of Arduino programming enabled utilization of readily accessible software that was easy to understand. Additionally, the overall design of the educational robot was easy to describe to the users. This agreed with Kim *et al.*, (2019) who designed a ROBOSTEM whose programming was based on easy-to-understand foundations in theory that were easily explained to the users. The adoption of the Raspberry Pi software to modify and enhance more user modifications was guided by Yamanoor and Yamanoor (2017) who noted that the Raspberry Pi software enhances robots of high quality at a very low cost. Additionally, the Raspberry Pi has various variants that are easy to code and those that can be easily manipulated for different learning tasks.

The structure of the educational robot was made of plastic materials. This came with two main advantages: one, the plastic materials are readily available and two, they are light. Therefore, learners can easily associate with the robot due to the utilization of readily available plastic materials. According to Xenaki and Brentas (2019), when educational robots are made of open software and locally available materials, learners easily understand the functionality of the robots. Thus, the learners can easily adopt them in different learning activities.

The educational robot in the current study differs from the readily available robots in the markets due to its flexibility, easy to assemble and reduced complexity of the microcontroller. These easily suited learners with no past knowledge in programming and skills linked to the design of robots. Based on this, learners would grasp concepts in a short time and also made it possible for learners to perform tasks in a straightforward and appealing manner. This would help in efficiency and boosting the learners' self-esteem (Tsalmpouris *et al.*, 2021). The ease in assembling and utilization of readily available materials is supported by Cano (2022) who reiterated that adoption of readily available materials and ease of assembling brings in a real-life atmosphere which motivates learners in using the robots. Further, students can relate with the tasks executed by the robots and can easily understand the robots' functionality. This can have a great effect on their creativity, attitude and motivation (Cano, 2022).

The designs supported the development of educational activities which made the Physics and Mathematics topics selected easier to understand. The Physics teachers interviewed gave positive sentiments in relation to the robot designs and as such it is worth noting that the designs can be concluded to be suitable for development of hands-on activities making learning of STEM subjects enjoyable.

Research in robot designs in development of learning activities in Kenya has not been popular in a formal set-up. Most of the robots employed for computational purposes are expensive and as such not many schools can afford the robots. Some of the available designs do not allow learners to explore the basic robot components in that they are enclosed and parts are presented as blocks. In this study the researcher fabricated robot that are flexible and affordable. Therefore, by presenting a less complex and cost-effective educational robot, this study breaks the barriers

encountered in the adoption and application of robotics in teaching such as large costs of equipment in addition to the closed designs and complex software offered by manufacturing companies. Additionally, most trainers lack the knowledge that is necessary on how to use ready-made robotics. The adoption of simple to learn design of the robots counters this barrier. The robotic design would therefore be ideal for adoption for educational purposes hence acting as a channel of opening up utilization of robotics to education.

#### **4.4 Robotic Activities for integration to Physics and mathematics**

Different robotic activities were developed to aid in learning basic programming skills for the robot functionality and to facilitate integration of the activities to Physics and Mathematics topics. Some of the activities developed included basic 3-D drawing activities, basic electronic activities, robot parts and assembly, robot parts programming, line following activities, obstacle avoidance activities, and robotic arm rotational dynamics activities. The activities developed were numerous and therefore the activities corresponding to the Physics and Mathematics topics learnt in Form 2 were the main focus in this Study. A brief description of these activities and their expected roles is as described in Table 4.3.

**Table 4.3: Developed Secondary School Robotic Activities**

<b>Developed Activity</b>	<b>Tasks related to the activity</b>	<b>Purpose of the activity</b>
Basic Technical drawing activities	Drawing of basic 2-D shapes like Square, rectangle, Circle, oval. Extruding the shapes to obtain 3D models	To demonstrate the design of robot parts
3D printing	Tasks involving printing of the 3D shapes developed	To demonstrate the printing of robot parts
Basic electronics activities	Measurements of basic electrical quantities tasks like resistance, electric current, voltage and power	Integration of the activities to Physics and Mathematics
Solar Photovoltaic activities	Measurement of solar energy components tasks. Tasks on various applications of solar energy and storage of energy.	To demonstrate energy conversion in Physics for Purposes of integration to Physics topics
Robot part identification and assembly	Tasks involving identification of types of Sensors and their applications, transducers, Tasks on involving types of dc motors, microcontrollers	To appreciate the importance of various robot parts. To integrate the activities in Physics topics
Basic programming.	Programming tasks on robot parts which majorly include sensors and motors	To appreciate how commands can be issued with the aim of controlling the robot car and arm
Line following robot activities.	Tasks involving creating different pathways with different shapes and colours. Tasks on Linear motion involving calculation of Speed and Acceleration Tasks involving determination of Area, Perimeter and Circumference	To integrate the activities in Physics and Mathematics topics
Obstacle avoidance robot activities.	Tasks involving waves reflection of waves, distance Calculation	To integrate the activities in Physics and Mathematics topics
Robotic arm rotational dynamics activities.	Tasks involving reflection and rotation, effects of a force, Angular motion, Circular motion, Objects Tasks involving objects in 3 dimensions space.	To conceptualize and integrate the various activities to Physics and Mathematics topics.

The developed activities were then integrated with the Physics and Mathematics. Using the robot car movement and the robotic arm rotation, several topics such as force, Light and sound, Linear and circular motion, Basic concepts of electricity, Geometry and friction were discussed. The integration process involved including the developed activities to be part of the hands-on activities to aid in learning topics in Physics and Mathematics as part of the curriculum. Therefore, themes were developed based on the nature of the activities and the topics in which the activities could be integrated. The integration process was done based on four themes which included;

- i. Interdisciplinary nature of the activities
- ii. Adaptability of the activities to educational settings
- iii. Interest and participation in Classroom activities
- iv. Problem solving

The theme on the interdisciplinary nature of the activities is shown in Table 4.4.

**Table 4.4: Themes in Integration of Robotic Activities in Physics and Mathematics**

<b>Theme</b>	<b>Activities for integration</b>	<b>Remarks on the Topics and subjects whose activities were integrated</b>
Interdisciplinary nature of the activities	Technical drawing activities. Drawing of basic shapes 2D and 3D	Geometry, Area and perimeter of Shapes in both Physics and Mathematics.
	Line following activities	Measurement of distance, time, speed. Linear motion. All in Physics and Mathematics.
	Basic programming activities	Programming of sensors and motors which involved Physics, Mathematics and programming techniques.
	Obstacle avoidance robot activities	Waves, Measurements, Sound which cuts across Physics and Mathematics
	Robotic arm rotational dynamics activities.	Turning effects of force, Rotation, Circular motion, measurement which involves the two subjects

The adaptability of the activities to educational settings, interest and participation in classroom activities and problem solving themes are shown in Table 4.5

**Table 4.5: Themes in Integration of Robotic Activities in Physics and Mathematics**

Theme	Activities for integration	Remarks on the Topics and subjects whose activities were integrated
Adaptability of the activities to educational settings	Basic electronics activities Basic programming. Robot part identification and assembly Line following robot activities. Obstacle avoidance robot activities. Robotic arm rotational dynamics activities.	Measurements Basic electricity Transducers, Power, work and energy Geometry, Angles, Circular motion, Rotation, Translation, Forces and Energy. The activities are adaptable in teaching the Physics and Mathematics topics indicated
Interest and participation in Classroom activities	Basic electronics activities Basic programming. Robot part identification and assembly Line following robot activities. Obstacle avoidance robot activities. Robotic arm rotational dynamics activities	The activities improved learners interest during lessons in the topics integrated with the activities. They also made abstract concepts clearer and more understandable
Individual and group problem Solving	Basic electronics activities Basic programming. Robot part identification and assembly Line following robot activities. Obstacle avoidance robot activities. Robotic arm rotational dynamics activities	The activities were implemented in groups and as such it improved learners' ability to work in teams. The activities made solving of problems easier in topics like Forces, Rotation, momentum among others

The students were exposed to the integrated activities during the workshops held at Murang'a University of Technology. The activities included robotic car activities like line following where the learners worked on topics like speed, measurement, friction and energy as shown in Figure 4.3.



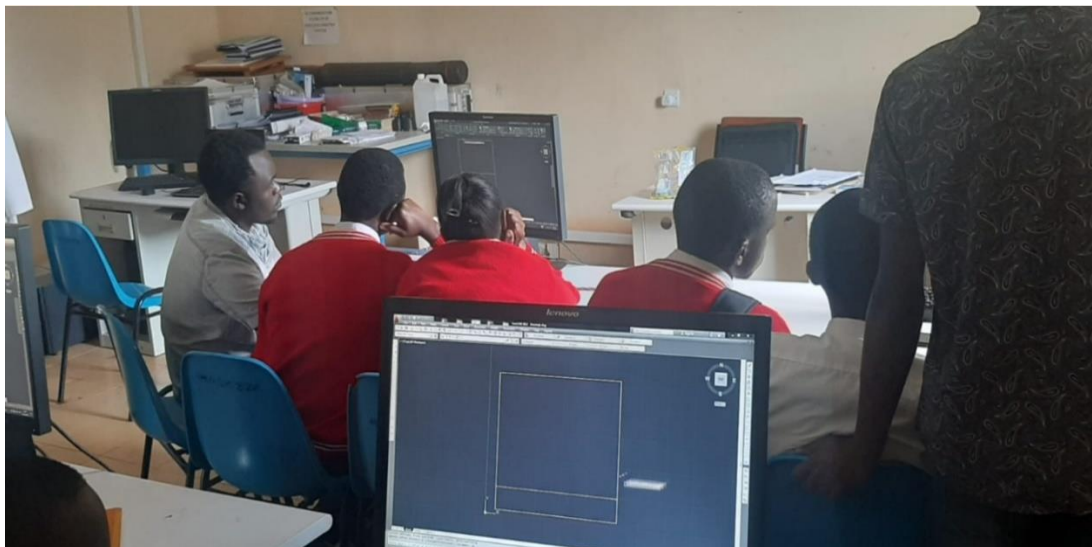
**Figure 4.3: Student Undertaking Line Following Activity**

The students also did activities involving robotic arm. The activities were related to Mathematics topics like rotation, reflection, angles and geometry as shown in Figure 4.4



**Figure 4.4: Students Undertaking Robotic Arm Activity**

Other activities included in the workshop included technical drawing activities as shown in Figure 4.5



**Figure 4.5: Technical Drawing Activities**

The students also undertook solar energy activities as shown in Figure 4.6



**Figure 4.6: Students doing Solar Energy Activities**

After participating in the developed robotic activities, the students were presented with questionnaire items where they were required to indicate their level of agreement or disagreement on the nature of the activities in terms of being fun and enjoyable, hands-



on (giving the learners a practical experience of what to expect in Engineering), interesting and exciting and whether they would be carried out with ease. The findings are as reported in Table 4.6.

**Table 4.6: Nature of Developed Robotic Activities**

	Strongly Disagree	Disagree	Neither Agree nor Disagree	Agree	Strongly Agree
It was fun and enjoyable to undertake the robotics activities	5 (2.6%)	5 (2.6%)	14 (7.3%)	87 (45.3%)	81 (42.2%)
The robotic activities gave me practical experience of what to expect in Engineering	5 (2.6%)	1 (0.5%)	17 (8.9%)	78 (40.6%)	91 (47.4%)
The robotic activities were interesting and exciting	11 (5.7%)	5 (2.6%)	14 (7.3%)	70 (36.5%)	92 (47.9%)
I would carry out the activities with a lot of ease	3 (1.6%)	5 (2.6%)	11 (5.7%)	76 (39.6%)	97 (50.5%)

From the results in Table 4.6, 45.3% (87) and 42.2% (81) of the learners agreed that it was fun and enjoyable to undertake the robotic activities; 7.3% (14) neither agreed nor disagreed, 2.6% (5) disagreed and another 2.6% (5) strongly disagreed. Further, 47.4% (91) and 40.6% (78) of the respondents strongly agreed and agreed respectively that the robotic activities gave them practical experience of what to expect in Engineering; 8.9% (17) neither agreed nor disagreed, 2.6% (5) strongly disagreed and 0.5% (1) disagreed. The findings also demonstrated that 47.9% (92) and 36.5% (70) of the participants strongly agreed and agreed respectively that the robotic activities were interesting and exciting; 7.3% (14) neither agreed nor disagreed, 5.7% (11) strongly disagreed and 2.6% (5) disagreed. Lastly, 50.5% (97) and 39.6% (76) of the learners strongly agreed and agreed respectively that they would carry out the robotic

activities with a lot of ease; 5.7% (11) neither agreed nor disagreed, 2.6% (5) disagreed and 1.6% (3) strongly disagreed.

#### **4.4.1 Key informants' opinions of the developed robotic activities**

Interviews were also carried out with the key informants so as to evaluate the suitability of the developed activities in the learning of Physics and Mathematics. The teachers admitted that they had faced numerous challenges explaining some Physics concepts and mathematical problems and therefore some suitable activities would be very useful in the teaching-learning process. To ascertain the suitability of the robotic activities, the researcher formed the basis of seeking opinions from the key informants. The researcher grouped the suitability of the activities into four categories. These included

- i. Ability to divide the activities into simple tasks
- ii. Nature of the tasks in relation to the level of learners
- iii. Ease of integration of the tasks to Physics and Mathematics topics
- iv. Hands-on learner centered tasks
- v. To unravel this, the guiding question was, "What would you say about the activities developed in terms of dividing them into simple tasks in Physics and Mathematics teaching topics?" It is worth noting that all teachers agreed that the activities developed from the robotic designs were suitable for teaching and learning of Physics and Mathematics since they could be divided into simple tasks. They gave various reasons on their opinions. The respondents noted that,

*“The robotic activities are vital in solving particular problems created in form of simple tasks and hence improving the learner’s ability to learn Physics and Mathematics and creativity thereof” (TPM 01, 2021)*

*“Learning is a process and as such it can be enhanced by practical activities which can be built from simple tasks advancing to more complex tasks. Educational robotics activities provide such tasks in Physics and Mathematics education. We cannot shy away from robotic activities” (TPM 03, 2021)*

*“The activities available for this workshop are learner friendly and have great connection with various topics in Physics and Mathematics. The simplicity of the activities gives learners a lot of confidence and exposure which makes it easy to introduce complex concepts with a lot of ease and in a gradual manner” (TPM 10, 2021).*

From these sentiments it can be concluded that the activities developed could be split into simple manageable tasks which would make learning easier and hence the activities are suitable and relevant for integration into Physics and Mathematics.

To further explore suitability of the activities in terms of the level of the learners, the guiding question was, “What would you say about the activities developed in terms of their suitability to the Form 2 learners in Physics and Mathematics?” Teachers agreed that the activities developed were properly suited in teaching most of the topics in Physics and Mathematics. Among the interviewed teachers noted that;

*“The activities are appropriate for the form 2 learners and can aid in teaching Physics and Mathematics. In Physics the activities aid in teaching and learning areas like*

*measurements, effects of forces while in Mathematics they can aid in topics like rotation and angles” (TPM4, 2021)*

*“The robotic activities developed are all round and good in that they can aid in understanding form 2 Physics and Mathematics. The robotic arm can be used in teaching Physics and Mathematics topics like Measurements, linear and circular motion, Trigonometry and rotation among others. The use of educational robotic activities can also be used in teaching 3-D concepts which makes easier for learners to visualize the 3 axis in 3 dimension” (TPM5, 2021)*

*“The activities prepared were fun themselves and made learning of Physics and Mathematics fun. They kept the learners awake and as such if adopted they will improve the understanding of the subjects” (TPM 8, 2021)*

Thus from these sentiments it is worth noting that the developed educational robotic activities were good, relevant and appropriate in teaching Form 2 Physics and Mathematics subjects in Secondary schools.

The teachers gave their opinions on the suitability of the activities on ease of integration of the tasks to Physics and Mathematics topics. They all agreed that the activities were easy to integrate in Physics and Mathematics and would make teaching of the subjects easier and clearer. To explore this, the guiding question was, “What would you say about the activities developed in terms of their ease of integration to Physics and Mathematics topics?” The teachers gave various reasons on their opinions. They noted that,

*“The robot activities were broken into simple tasks which when used in teaching and learning Physics and Mathematics could assist in simplifying hard concepts in the subjects with the robots acting as demonstration aids hence improving understanding of the subjects. They help in mastery of science subjects” (TPM1, 2021)*

*“The tasks incorporated in the Physics and Mathematics topics play a great role in making clear some abstract concepts in the subjects” (TPM2, 2021)*

*“The good thing with the activities developed was that in them various concepts in Mathematics and Physics could be seen. The students themselves would easily identify the topics related to the activities. As a teacher in these subjects, my take is that the activities can easily be integrated to the aforesaid subjects which would make teaching and learning of the subjects very interesting “(TPM 7, 2021)*

From the sentiments by those interviewed it can be concluded that the developed educational robotic activities can be integrated into Physics and Mathematics and would make these subjects more interactive. This would in turn improve the learners’ ability to understand the various Physics and Mathematics topics.

The teachers gave their opinions on the suitability of the activities in terms of their hands-on, learner centered nature. They all agreed that the activities were hand-on and learner centered. To explore this, the guiding question was, “What would you say about the nature of the activities developed in terms of their hands-on and learner centered nature?” The teachers gave various reasons on their opinions. They noted that,

*“Physics and Mathematics are practical subjects. The activities in this workshop were hands-on and learner centered. The activities bring to the learners, the real-life*

*situations for instance rotation of the robotic arm where the learners can relate the rotation of the arm with rotation in Mathematics. This promotes understanding of the subjects.” (TPM3, 2021)*

*“In teaching of Physics and Mathematics, the activities can aid learners in understanding of topics like measurements, effects of forces, rotation and angles since they are hands-on” (TPM4, 2021)*

*“The learners could perform the activities on their own and found them very interesting and made learning of the Physics and Mathematics topics more interesting thereby improving understanding. The use of robotic arm made the topic on rotation very practical and real” (TPM7, 2021)*

From the questionnaire responses, it is evident that the learners perceived the developed activities as fun and enjoyable, hands-on, interesting and exciting and could be carried out with ease. These findings concur with Ziaeefard *et al.*, (2017) who stated that while developing robotic activities, the activities developed should possess factors that align with the RAAS. The fact that the activities developed in this study were hands-on gave learners an overview of what would be expected in Engineering (real-life experiences in Engineering). Additionally, the activities developed were fun and enjoyable, interesting and exciting thus aligning with motivation and interest outlined by RAAS as applied by Ziaeefard *et al.*, (2017) and defined by Cross *et al.*, (2016).

From the sentiments by those interviewed it can be concluded that the developed educational robotic activities were hands-on and can make Physics and Mathematics subjects in Secondary schools more interactive and hence improve the learners' ability

to understand the various Physics and Mathematics topics. They can promote the learning process of Physics and Mathematics and other STEM subjects.

From the study, it is evident that activities such as basic technical drawing, 3-D printing, basic electronics, solar photovoltaic, identification of robot parts and assembly of the robot, basic programming, line-following, obstacle avoidance and robotic arm rotational dynamics activities were developed. The aim was to ensure that the activities are well defined into tasks that would help in understanding the functionality of the developed robotic kit, help in understanding basic programming and facilitate in integrating the activities to topics in Physics and Mathematics. This agreed with Screpanti *et al.*, (2018) who noted that development of educational robotic activities should involve tasks that will enable users to familiarize with the use and functionality of robots. During the development of robotic activities, users learn tasks on the use of robotic kit and learn how to build, modify and programme robots for a given task (Jung & Won, 2018).

From the study, it was evident that the researcher further assessed the suitability of the robotic activities based on four categories which included ability to sub-divide the activities into tasks that were simple, nature of the tasks in relation to the learners' levels, ease of integration of the tasks to Physics and Mathematics and hands-on learner centered tasks. The responses indicated that the activities could be divided into simple tasks that matched the level of learning for the participants. Additionally, the tasks were hands-on learner centered and could easily be integrated to teaching Physics and Mathematics.

In a project by Chen and Chang (2018), the development of robotic activities in sailboat robots adopted a task-centered model where the entire project was divided into tasks that helped users to familiarize with the sailboat robot. With each task requiring different skills and concepts, the users can easily understand the components and functioning of a robot making it easy for integration in selected STEM topics (Chen & Chang, 2018). Further, Scaradozzi *et al.*, (2020) stated that development of activities should enable the users to create and experiment with the robot, making the entire project learner-centered. In such a way, users will engage in activities that will provoke thinking and creativity, making, and improving the robot, making it easier to integrate the robotic activities in teaching STEM related topics.

#### **4.4.2 Key informants' opinions of the integrated robotic activities**

The key informants were presented with several questions in interview in which they were supposed to respond on the relevance of the themes developed to integration of robotic activities to Physics and Mathematics. The key informants were asked on the nature of the activities integrated through the guiding question “What is your opinion about the nature of the robotic activities integrated to Physics and Mathematics topics done in this workshop?” It is worth noting that the teachers agreed that the activities were interdisciplinary in nature and as such most of them could be used in teaching Physics and Mathematics. This is supported by the sentiments given by the teachers. One teacher noted;

*“The activities are hands on and could be used in demonstration of hard concepts in both Physics and Mathematics” (TPM 1, 2021)*

Another teacher, TPM 5, noted:



*“Some of the activities integrated in the various topics worked perfectly well. The robotic arm for instance could be used to teach topics like rotation, geometry, vectors among others in Mathematics and can also be used in teaching force and circular motion in Physics” (TPM 5, 2021)*

Teacher, TPM 9 added that:

*“The integration of the robot activities to Physics and Mathematics is the best thing that can happen. The activities integrated in Physics and Mathematics in this Workshop could double in teaching Physics and Mathematics” (TPM 9, 2021)*

From these sentiments it can be concluded that some of the activities integrated in the Physics and Mathematics topics are interdisciplinary in nature and as such the integration would be beneficial to the learning of the two subjects.

The key informants agreed that the activities were adaptable to the educational settings and as such most of them could be used in teaching Physics and Mathematics.

This is supported by the sentiments given by the teachers. The teachers noted;

*“The activities made the teaching and learning of Physics and Mathematics more practical. I advocate for the integration of the activities in that as a teacher the activities are not difficult to implement.” (TPM 7, 2021)*

*The integrated activities fitted properly to Physics and Mathematics topics. When teaching and learning these topics the activities compliment the process. The same activities can be integrated to several topics hence making the learners see the connection of the topics thereby appreciating every topic (TPM 9, 2021)*

Another teacher noted;

*“The activities are useful in that they boost understanding by the students. They can aid both teachers and students in the teaching learning process. With a little bit of creativity, the activities could teach even more topics” (TPM 10, 2021)*

From these sentiments it can be concluded that the activities are adaptable to the educational settings.

In order to explore the effects of the activities in classroom participation of the learners a guiding question was posed to the teachers “What is your opinion on the effects of the integrated robotic activities to learners’ interest and classroom participation?” The teachers agreed that the activities made the learners more active in the sessions.

The following sentiments were given by the teachers during the interview;

*“The use of the robots and activities developed from them was very exciting to the learners. The learners were actively participating in the classroom activities. The activities were eye opening and would adequately support our teaching of Physics and Mathematics” (TPM 6, 2021)*

*“There have not been many practicals in teaching and learning of the Mathematics. The learners were very excited and alert as they participated actively in the learning activities” (TPM 8, 2021).*

*“The learners find the activities to be fun. Some difficult concepts became easier for them to visualize with the use of the activities. Their participation in the learning process changed positively” (TPM 9, 2021)*

From these sentiments it can be seen that the activities improved learners’ interest and participation in the learning process during the workshop sessions.

A guiding question was also posed to the teachers in order to assess whether the activities would assist improve problem solving: “What is your opinion on how the integrated robotic activities affected learners’ problem-solving abilities as individuals and in a group setting?” The teachers agreed that the activities contributed immensely to the problem-solving abilities of the learners individually and also in groups.

The following sentiments were given by the teachers during the interview;

*“The activities can spur critical thinking and problem-solving skills of the learners. The way the learners carried out the activities is enough evidence for that” (TPM 2, 2021)*

*“The integrated activities which included some simple projects indeed helped the learners think outside the box. The learners could be able to solve simple problems as individuals and when working together” (TPM 4, 2021)*

*The activities carried out in groups enhanced collaboration of learners. These activities can promote team work spirit in the classroom learning. The learners can combine their abilities and develop greater problem solving skills enhanced by group work (TPM 6, 2021)*

It can therefore be concluded that the integrated activities can improve the learners’ abilities to solve problems including real live problems. It can additionally improve the team work spirit in the learning process.

The integration of the robotic activities followed four themes: interdisciplinary, adaptability, interest and participative, individual and group problem solving themes. This ensured that the developed activities were integrated into teaching Physics and Mathematics in groups of activities rather than individually. As such, the integration

would enhance creativity, innovation and excite learners while being taught different topics in Physics and Mathematics. While integrating different robotic activities in teaching STEM subjects, the curriculum for the subjects under consideration should be restructured into themes so as to align it within the project of the educational robots (Ntemngwa & Oliver, 2018). Through this, teachers can simply fit simple instructions into a theme that is already in existence, thus making it easier to incorporate robots in learning.

According to Chen and Chang (2018), integration of activities in teaching STEM should adopt a theme that is interdisciplinary, requiring concepts drawn from different science, Mathematics and Engineering units. The same notion is anchored in Benitti and Spolaor (2017) who supported the need for educational robots to be flexible thus facilitating integration across different disciplines in the curriculum.

While integrating the activities, the themes interest & participation and individual & group problem solving were guided by ALC which facilitated project-based learning. In Ching *et al.*, (2019), integration of activities in the curriculum should adopt an approach that enables the structuring of the entire curriculum by offering an opportunity to the learners to investigate topics or problems that are authentic. The integrated activities should ensure that learners engage in learning STEM related units through real creation of artifacts with teachers only acting as facilitators during the activities.

The development of the themes in this study fostered creativity and innovativeness by the learners. By the fact that a theme contained different activities, learners had the opportunity of understanding how a group of activities can be applied in solving

problems in Physics and Mathematics. Learners would also be given a chance to think of activities' combination that would be applicable for different topics in Physics and Mathematics. However, this was done in line with the curriculum. This aligned with Scaradozzi *et al.*, (2015) who stated that the aim of integrating activities should be to expose students to hands-on opportunities that push them to be creative and innovative in applying the knowledge and skills that they already possess (Scaradozzi *et al.*, 2015).

The developed themes during integration also ensured that teachers would fit simple instructions into an already existing theme during teaching. According to Khanlari and Mansourkiaie (2015), integrated activities should involve STEM topics that can easily be taught using educational robotics and ones which do not need complex modifications of the educational robotics.

#### **4.5 Quantitative data findings**

This section presents the quantitative findings of the third and the fourth objectives. The response rate, the personal information and the participants are highlighted. The results the objectives are then discussed after the preliminary information

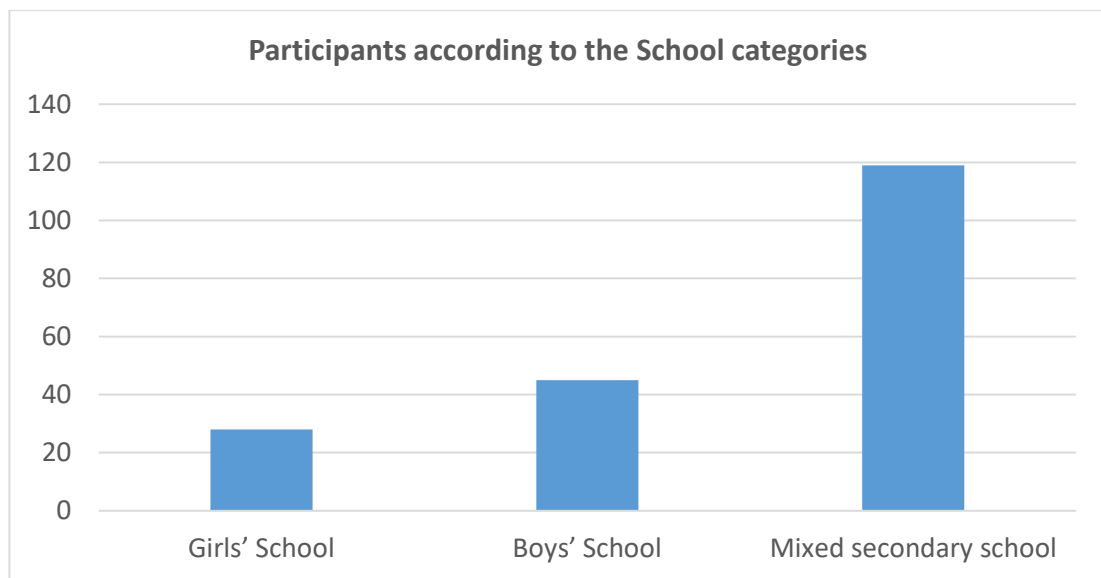
##### **4.5.1 Response Rate**

The study was conducted among 270 Form 2 students selected from 27 schools in Kangema Sub-County: 3 girls' schools, 5 boys' schools and 19 mixed secondary schools. This implied that, 30 girls were selected from girls' only secondary schools, 50 boys from boys' only secondary school and 190 from mixed secondary schools. The response rate for each category and the overall response rate were as reported in Table 4.7.

**Table 4.7: Response Rate**

Category	Frequency	Return Rate %
Girls' School	28	93.3%
Boys' School	45	90.0%
Mixed Secondary School	119	62.6%
Overall return rate	192	71.1%

The actual number of the students from the three school categories who responded and whose questionnaires were considered in the research process is shown in Figure 4.7



**Figure 4.7: Participants according to the School Categories**

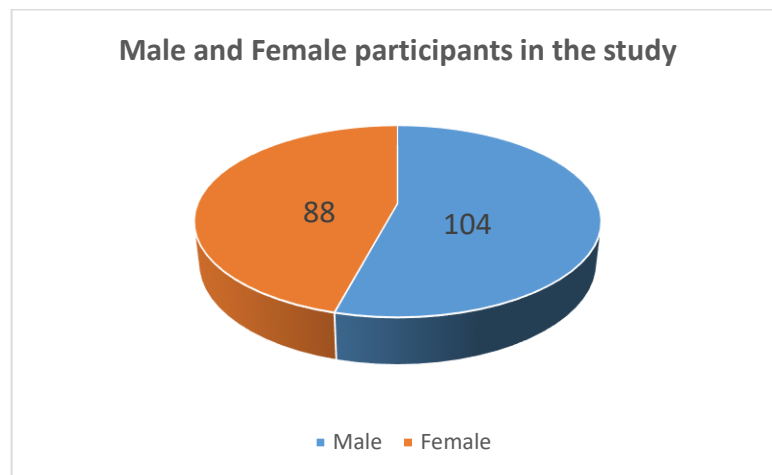
#### 4.5.2 Personal Information

The respondents were required to indicate the nature of their school, gender and current class. From the findings as reported in Table 4.7, 49.0% (94) were from mixed schools, 27.6% (53) were from boys' school and 23.4% (45) were from girls' school. The findings also indicate that 54.2% (104) were male and 45.8% (88) were female. All the respondents, 100.0% (192) were in Form 2.

**Table 4.8: Personal Information of the Students**

		<b>Frequency</b>	<b>%</b>
<b>School Category</b>	Girls School	28	14.6%
	Boys School	45	23.4%
	Mixed School	119	62.0%
<b>Gender of Participant</b>	Male	104	54.2%
	Female	88	45.8%

From these findings, it is evident that all the school categories were represented in the study with fair distribution across male and female students. The findings also show that both boys and girls were well and adequately represented in the study. The distribution of participants as per their gender is shown in Figure 4.8.



**Figure 4.8: Gender of the Participants**

#### **4.6 The effect of Integration of Robotic Activities to perception of Physics and Mathematics**

In order to examine the effects that the integration of the developed activities to learners' perception of Physics and Mathematics topics, the researcher formed the basis of seeking opinion from the students. The students were therefore presented with questionnaire items that examined how the integrated activities aided in understanding of Physics and Mathematics, made learning of Physics and Mathematics fun, enhanced

creativity, interest & motivation and how the integrated activities made Physics and Mathematics easier. The students were presented with these items prior and after exposure to the educational robot. The pretest responses findings are reported herein.

#### 4.6.1 Pre-test findings on perception

On a Likert scale of Strongly Disagree to Strongly Agree, the participants were presented with several statements regarding robotic activities and integration in Physics and Mathematics. The findings are as presented in Table 4.9.

**Table 4.9: Pretest Results Integration of Activities and Students' Perception of Physics and Mathematics**

	Strongly Disagree	Disagree	Neither Agree nor Disagree	Agree	Strongly Agree
The use of robotic activities in learning various topics in Physics and Mathematics can aid in understanding the sciences	6 (3.1%)	5 (2.6%)	35 (18.2%)	102 (53.1%)	44 (22.9%)
The use of the robotic activities can make learning of Physics and Mathematics fun	3 (1.6%)	13 (6.8%)	43 (22.4%)	82 (42.7%)	51 (26.6%)
The use of the robotic activities in learning of Physics and Mathematics can improve my creativity	0 (0.0%)	7 (3.6%)	36 (18.8%)	86 (44.8%)	63 (32.8%)
Integration of robots in educational activities could raise the interest of the students in participating in the classroom activities	16 (8.3%)	19 (9.9%)	62 (32.3%)	59 (30.7%)	36 (18.8%)
Educational robotics should be used as a learning object to motivate student's classroom instruction on Physics and Mathematics Education	12 (6.2%)	23 (12.0%)	55 (28.6%)	61 (31.8%)	41 (21.4%)
Educational Robotics can aid in making learning of Physics and Mathematics topics easier	23 (12.0%)	27 (14.1%)	38 (19.8%)	65 (33.9%)	39 (20.3%)



Table 4.9 shows that 53.1% (102), 22.9% (44), 18.2% (35), 3.1% (6) and 2.6% (5) of the participants indicated that they agreed, strongly agreed, neither agreed nor disagreed, strongly disagreed and disagreed respectively that the use of robotic activities in learning various topics in Physics and Mathematics aid in understanding the sciences. The statement “The use of the robotic activities made learning of Physics and Mathematics fun” had 42.7% (82), 26.6% (51), 22.4% (43), 6.8% (13) and 1.6% (3) of the students agree, strongly agree, neither agree nor disagree, disagree and strongly disagree. Table 4.8 also shows that 44.8% (86) and 32.8% (63) of the students agreed and strongly agreed that the use of robotic activities in learning of Physics and Mathematics improved their creativity; 18.8% (36) neither agreed nor disagreed and 3.6% (7) disagreed.

In total, 49.5% (95) of the respondents agreed and strongly agreed that integration of robots in educational activities could raise the interest of the students in participating in the classroom activities; 32.3% (62) neither agreed nor disagreed, 9.9% (19) disagreed and 8.3% (16) strongly disagreed. Also evident from the findings is that 31.8% (61) and 21.4% (41) of the respondents agreed and strongly agreed that educational robotics should be used as a learning object to motivate students’ classroom instruction on Physics and Mathematics education; 28.6% (55) neither agreed nor disagreed, 12.0% (23) disagreed and 6.2% (12) strongly disagreed. The findings also showed that 54.2% (104) of the respondents agreed and strongly agreed that educational robotics aid in making learning of Physics and Mathematics topics easier.

#### 4.6.2 Post-test findings on perception

After being exposed to the educational robot, and working with the robots on their own, the students were presented with the same questionnaire items. The Likert scale responses on robotic activities and integration are as presented in Table 4.10.

**Table 4.10: Post-test Results Integration of Activities and Students' Perception of Physics and Mathematics**

	Strongly Disagree	Disagree	Neither Agree nor Disagree	Agree	Strongly Agree
The use of robotic activities in learning various topics in Physics and Mathematics aided in understanding the sciences	3 (1.6%)	4 (2.1%)	5 (2.6%)	90 (46.9%)	90 (46.9%)
The use of the robotic activities made learning of Physics and Mathematics fun	3 (1.6%)	0 (0.0%)	13 (6.8%)	82 (42.7%)	94 (49.0%)
The use of the robotic activities in learning of Physics and Mathematics improved my creativity	6 (3.1%)	2 (1.0%)	9 (4.7%)	76 (39.6%)	99 (51.6%)
Integration of robots in educational activities raised the interest of the students in participating in the classroom activities	4 (2.1%)	4 (2.1%)	52 (27.1%)	83 (43.2%)	49 (25.5%)
Educational robotics should be used as a learning object to motivate student's classroom instruction on Physics and Mathematics Education	8 (4.2%)	12 (6.2%)	39 (20.3%)	66 (34.4%)	67 (34.9%)
Educational Robotics aid in making learning of Physics and Mathematics topics easier	5 (2.6%)	5 (2.6%)	29 (15.1%)	66 (34.4%)	87 (45.3%)

From the findings, 46.9% (90), another 46.9% (90), 2.6% (5), 2.1% (4) and 1.6% (3) of the respondents strongly agreed, agreed, neither agreed nor disagreed, disagreed and strongly disagreed respectively that the use of robotic activities in learning various

topics in Physics and Mathematics aid in understanding the sciences. From the findings, it is evident that 49.0% (94), 42.7% (82), 6.8% (13) and 1.6% (3) of the respondents strongly agreed, agreed, neither agreed nor disagreed and strongly disagreed respectively that the use of robotic activities made learning of Physics and Mathematics fun. It is also clear that 51.6% (99) of the participants strongly agreed that the use of robotic activities in learning of Physics and Mathematics improved their creativity; 39.6% (76) agreed, 4.7% (9) neither agreed nor disagreed, 3.1% (6) strongly disagreed and 1.0% (2) disagreed.

The findings also showed that a total of 68.7% (132) of the respondents agreed and strongly agreed that integration of robots in educational activities could raise the interest of the students in participating in the classroom activities; 27.1% (52) neither agreed nor disagreed, 2.1% (4) disagreed and another 2.1% (4) strongly disagreed. The results also showed that 69.3% (133) of the respondents agreed and strongly agreed that educational robotics should be used as a learning object to motivate students' classroom instruction on Physics and Mathematics education; 20.3% (39) neither agreed nor disagreed, 6.2% (12) disagreed and 4.2% (8) strongly disagreed. From the results, it is also evident that 45.3% (87), 34.4% (66), 15.1% (29), 2.6% (5) and 2.6% (5) of the participants strongly agreed, agreed, neither agreed nor disagreed, disagreed and strongly disagreed respectively that educational robotics aid in making learning of Physics and Mathematics easier.

General observation of the pretest and posttest results reveal differences in responses on questionnaire items regarding the themes developed. Through a paired sample t-test, the difference in the responses was assessed. First, the variables (items) under the 'robotic activities and integration' were compressed into one pretest variable, pre-

robotic Secondary School activities integration, and one posttest variable, post robotic Secondary School activities integration, through the use of the mean for the 5 items in this section. Paired sample t-test was then conducted. The null hypothesis tested was:  $H_{01}$ : The integrated robotic activities had no significant effect on students' perception of Physics and Mathematics.

From the paired sample statistics, the mean for the pretest responses is lower, pretest mean=3.9708, as compared to the mean for the posttest responses, posttest mean=4.4094 (see Table 4.11).

**Table 4.11: Means on Pre-Robotic and Post-Robotic Integration of Activities**

		Mean	N	Std. Deviation	Std. Error Mean
Pair 1	Pre-robotic activities integration	3.9708	192	.64685	.04668
	Post-robotic activities integration	4.4094	192	.61950	.04471

The paired samples test shows that the  $p$ -value $<0.0001$  (see Table 4.11). This indicates that there is sufficient evidence to reject the null hypothesis. It can therefore be concluded that the two means are significantly different. The fact that the posttest mean is greater is a clear indication that the themes developed during robotic activities integration in teaching Physics and Mathematics significantly improve students' perception on understanding, fun, creativity, motivation and interest as a result of using robotic activities in learning of Physics and Mathematics.

**Table 4.12: Paired Sample t-test on Pre-Robotic and Post-Robotic Activities Integration**

		Paired Differences					T	Df	Sig. (2-tailed)
		Mean	Std. Deviation	Std. Error Mean	95% Confidence Interval of the Difference				
					Lower	Upper			
Pair 1	Pre-robotic activities integration – post-robotic activities integration	-.43854	.88476	.06385	-.56449	-.31260	-6.868	191	.000

In this study, robotic activities were integrated in various Physics and Mathematics topics. The activities could be employed in teaching both Physics and Mathematics and were thus interdisciplinary. The activities equally elicited a lot of interest in learning of the selected topics and promoted the learners' participation in the learning process. The learners would also handle the activities individually and as a team. The integration of such activities in to the secondary school syllabus would improve learners' interest and most importantly perception of the Science subjects and thereby improving performance and learners' perception towards these subjects.

#### **4.7 Assessing the Impact of Robotic Activities on Students' interest towards Engineering Career Pathways**

The fourth objective assessed the impact of robotic activities on students' interest towards Engineering career pathways. The students were presented with questionnaire items before and after exposure to the educational robot. The questionnaire evaluated the students on their personal information, background on their perception of Physics and Mathematics activities, background on robots, impact of robotic activities and career choice. The aim of presenting the questionnaire before and after exposure was to evaluate whether the learners changed their decision in choosing subject

combination towards an Engineering career, Background on robots, impact of robotic activities and career interest.

#### 4.7.1 Pre-test Findings on Impact or robotic activities

Students were presented with some statements regarding the background on Physics and Mathematics activities. The statements were on whether the classes were fun, whether they engaged on activities that helped in understanding the two subjects and how often the activities they engaged in improved the understanding of Physics and Mathematics. The findings are as reported in Table 4.13.

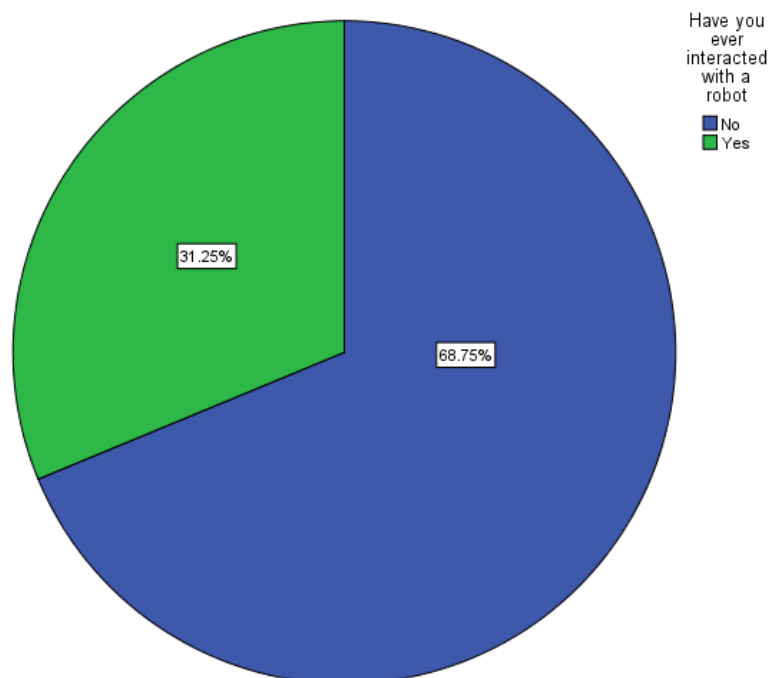
**Table 4.13: Pretest Background on Physics and Mathematics**

	Never	Rarely	Sometimes	Often	Always
How often are Physics and Mathematics classes fun?	0 (0.0%)	7 (3.6%)	45 (23.4%)	32 (16.7%)	108 (56.2%)
How often have you engaged in activities that aid understanding Physics and Mathematics	5 (2.6%)	23 (12.0%)	62 (32.3%)	49 (25.5%)	53 (27.6%)
How often have these activities improved your understanding in Physics and Mathematics	10 (5.2%)	12 (6.2%)	51 (26.6%)	33 (17.2%)	86 (44.8%)

From the results of the study, 56.2% (108) of the students indicated that Physics and Mathematics classes are always fun, 23.4% (45) indicated that Physics and Mathematics classes are sometimes fun, 16.7% (32) were of the opinion that Physics and Mathematics classes are often fun while 3.6% (7) indicated that Physics and Mathematics classes are rarely fun. Also evident from the findings is that 32.3% (62) of the respondents indicated that they sometimes engage in activities that aid in understanding of Physics and Mathematics, 27.6% (53) indicated that they always engage in activities that aid understanding of Physics and Mathematics, 25.5% (49) were of the opinion that that they sometimes engage in activities that aid understanding of Physics and Mathematics, 12.0% (23) rarely engaged in activities that aid understanding of Physics and Mathematics and 2.6% (5) never engaged in activities

that aid in understanding of Physics and Mathematics. From the findings, it is notable that 44.8% (86) of the students indicated that these activities always improved their understanding of Physics and Mathematics, 26.6% (51) indicated that the activities sometimes improved their understanding of Physics and Mathematics, 17.2% (33) opined that the activities engaged in often improved their understanding of Physics and Mathematics, 6.2% (12) indicated that the activities rarely improved their understanding of Physics and Mathematics and 5.2% (10) were of the opinion that the activities never improved their understanding of Physics and Mathematics.

The respondents were required to indicate whether they had previously interacted with a robot prior to this study, and if they had interacted, to indicate the duration that they interacted with the robots. The results as shown in Figure 4.9 indicate that majority of the students, 68.8% (132) had never interacted with a robot prior to the current study; 31.2% (60) indicated that they had interacted with a robot prior to the current study.



**Figure 4.9: Responses on Prior Interaction with a Robot**

Out of those who had interacted with a robot, 51.7% (31) indicated that they had interacted with a robot for 0-1 week, 31.7% (19) had interacted with a robot for 2-3 weeks while 16.7% (10) had interacted with a robot for 4 weeks and above (see Table 4.14).

**Table 4.14: Pretest Background on Robots**

		Frequency	%
Have you ever interacted with a robot	No	132	68.8%
	Yes	60	31.2%
If yes for how long	0-1 week	31	51.7%
	2-3 weeks	19	31.7%
	4 weeks and above	10	16.7%

Further, the respondents were required to respond on a Likert scale of “To no extent” to “To a very great extent” whether exposure to robots gave them a better understanding of science subjects and what to expect in the Engineering career. They were also required to indicate the extent to which exposure to Engineering through robotic activities changed their perception of Physics and Mathematics. The findings are as indicated in Table 4.15.



**Table 4.15: Pretest Findings on Impact of Integration of Activities**

	To no extent	To a lower extent	To a moderate extent	To a great extent	To a very great extent
In your own opinion, would you say the exposure to robotic car and robotic arm can give you a better understanding of the science subjects you learn in class	23 (12.0%)	26 (13.5%)	78 (40.6%)	50 (26.0%)	15 (7.8%)
In your own opinion, would you say the exposure to robotic car and robotic arm can give you a better understanding of what to expect in the Engineering career	17 (8.9%)	19 (9.9%)	73 (38.0%)	67 (34.9%)	16 (8.3%)
In your own opinion, to what extent do you think the exposure to Engineering through robotic activities can change interest in Physics and Mathematics?	17 (8.9%)	30 (15.6%)	111 (57.8%)	30 (15.6%)	4 (2.1%)
The use of the robotic activities in learning of Physics and Mathematics can improve my attitude towards the subjects	14 (7.3%)	22 (11.4%)	41 (21.4%)	74 (38.5%)	41 (21.4%)
The use of the robotic activities if introduced in the curriculum can improve students attitudes in Physics and Mathematics	21 (10.9%)	23 (12.0%)	41 (21.4%)	53 (27.6%)	54 (28.1%)

From the findings, 40.6% (78) indicated that exposure to robotic car and robotic arm can give them a better understanding of the science subjects they learn in class to a moderate extent; 26.0% (50) to a great extent, 13.5% (26) to a lower extent, 12.0% (23) to no extent and 7.8% (15) to a very great extent. From the findings, 38.0% (73), 34.9% (67), 9.9% (19), 8.9% (17) and 8.3% (16) of the respondents were of the opinion that exposure to robotic car and robotic arm can give them a better understanding of what to expect in the Engineering career to a moderate extent, to a great extent, to a lower extent, to no extent and to a very great extent respectively. The findings also demonstrate that 57.8% (111) of the respondents indicate that exposure

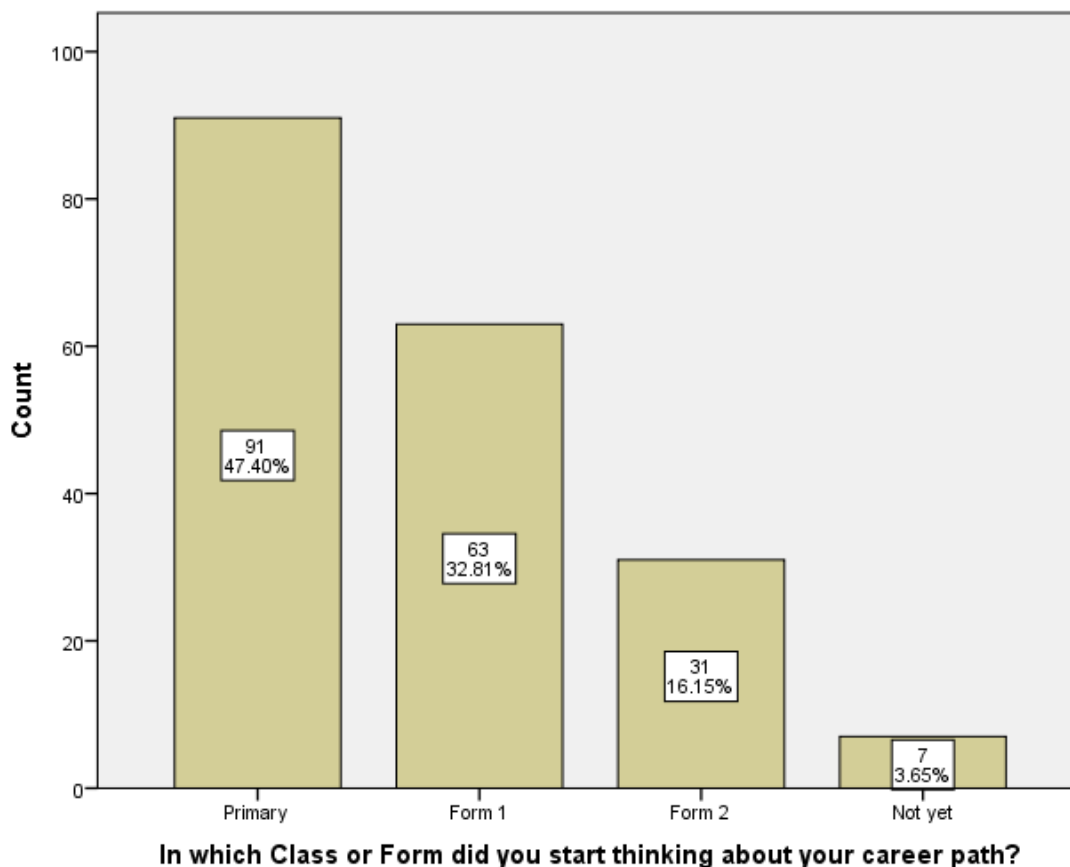
to Engineering through robotic activities changed their interest in Physics and Mathematics to a moderate extent; 15.6% (30) indicated to a great extent, another 15.6% (30) indicated to a lower extent, 8.9% (17) to no extent and 2.1% (4) to a very great extent. According to 38.5% (74) and 21.4% (41) of the learners who agreed and strongly agreed, the use of robotic activities in learning of Physics and Mathematics improved their attitudes towards the subjects; 21.4% (41) neither agreed nor disagreed, 11.4% (22) disagreed and 7.3% (14) strongly disagreed. From the responses, 27.6% (53) and 28.1% (54) of the learners agreed and strongly agreed respectively that the use of robotic activities should be introduced in the curriculum to improve students' attitudes in Physics and Mathematics.

The respondents were required to respond to some items regarding their career choice, for instance, whether they wanted to be scientists after leaving school, whether Physics and Mathematics were important as they prepared for their future career, which class they started thinking about their career pathways and the course they would pursue after completing secondary school. The findings are as shown in Table 4.16.

**Table 4.16: Pretest Findings on Career Interest**

		<b>Frequency</b>	<b>Percent (%)</b>
In which Class or Form did you start thinking about your career pathways?	Primary	91	47.4%
	Form 1	63	32.8%
	Form 2	31	16.1%
	Not yet	7	3.6%
I would like to be a scientist when I leave school	No	39	20.3%
	Not sure	112	58.3%
	Yes	41	21.4%
Physics and Mathematics are important to me as I prepare for my future career	No	13	6.8%
	Not sure	120	62.5%
	Yes	59	30.7%
I will select Physics as part of my subjects combination at the end of Form 2 level	No	14	7.3%
	Not sure	121	63.0%
	Yes	57	29.7%
Indicate the course you would want to pursue after doing your KCSE?	Art related course	31	16.1%
	Pure and applied sciences course	24	12.5%
	Engineering course	76	39.6%
	Health sciences course	38	19.8%
	Any other	23	12.0%

Evident from the findings as shown in Figure 4.10 and Table 4.15 is that 47.4% (91) of the respondents started thinking about their career pathways in primary level, 32.8% (63) started thinking at Form 1, 16.1% (31) started thinking about their career in Form 2 while 3.6% (7) have not yet thought about their career.



**Figure 4.10: Class when Participant Started thinking about Career Pathways**

It is clear from the findings in Table 4.10 that 58.3% (112) of the students were not sure whether they would like to be scientists when the complete form 4, 21.4% (41) indicated that they would like to be scientists upon completing Form 4 while 20.3% (39) indicated they would not want to be scientists upon completing Form 4. From the findings, 62.5% (120) of the respondents were not sure whether Physics and Mathematics are important to them as they prepare for their future career, 30.7% (59) indicated that they were sure that Physics and Mathematics are important to them as they prepare for their future career and 6.8% (13) were of the opinion that Physics and Mathematics were not important as they prepared for their future career. The findings also showed that 63.0% (121) of the respondents indicated that they were not sure whether they would select Physics as part of their subjects' combination at the end of

their Form two; 29.7% (57) indicated that they would select Physics and 7.3% (14) indicated that they would not select Physics at the end of their Form 2.

The respondents were required to list their preferred career. From the responses, the career choices were classified into Art, pure and applied science, Engineering, health sciences and any other categories. From the findings, 39.6% (76) indicated that they would pursue an Engineering course, 19.8% (24) indicated they would pursue a health sciences course, 16.1% (31) would pursue an art related course, 12.5% (24) would pursue a course in pure and applied sciences and 12.0% (23) would pursue any other course that was not part of the categories created.

#### 4.7.2 Post-test Results

The same questionnaire, as used in the pretest, was presented to the students after interacting with the educational robot. The posttest findings on statements regarding the background on Physics and Mathematics activities are as shown in Table 4.17.

**Table 4.17: Posttest Background on Physics and Mathematics**

	<b>Never</b>	<b>Rarely</b>	<b>Sometimes</b>	<b>Often</b>	<b>Always</b>
How often are Physics and Mathematics fun?	1 (0.5%)	5 (2.6%)	40 (20.8%)	56 (29.2%)	90 (46.9%)
How often have you engaged in activities that aid understanding Mathematics and Physics?	0 (0.0%)	16 (8.3%)	68 (35.4%)	57 (29.7%)	51 (26.6%)
How often have these activities improved your understanding in Physics and Mathematics?	1 (0.5%)	8 (4.2%)	43 (22.4%)	62 (32.3%)	78 (40.6%)

From the results, 46.9% (90) of the students demonstrated that Physics and Mathematics are always fun, 29.2% (56) indicated that Physics and Mathematics are often fun, 20.8% (40) indicated that Physics and Mathematics are sometimes fun, 2.6% (5) indicated that they are rarely fun and 0.5% (1) indicated that they are never fun.

From the table, it is clear that 35.4% (68) of the respondents indicated that they have sometimes engaged in activities that aid understanding Physics and Mathematics, 29.7% (57) indicated that they often engage in activities that aid understanding of Physics and Mathematics, 26.6% (51) indicated that they always engage in activities that aid in understanding of Physics and Mathematics and 8.3% (16) rarely engaged in activities that aid in understanding of Physics and Mathematics. It is notable from the findings as presented in Table 4.17 that 40.6% (78) of the respondents indicated that these activities always improved their understanding in Physics and Mathematics, 32.3% (62) indicated that the activities often improved their understanding in Physics and Mathematics, 22.4% (43) were of the opinion that these activities sometimes improved their understanding in Physics and Mathematics, 4.2% (8) opined that these activities rarely improved their understanding of Physics and Mathematics and 0.5% (1) indicated that these activities never improved an understanding of Physics and Mathematics.

The posttest findings regarding the background on robotics are as shown in Table 4.18. All the respondents, 100.0% (192) indicated that they had interacted with a robot. Out of these respondents, 59.4% (114) indicated that they had interacted with a robot for 2-3 weeks, 20.8% (40) indicated that they had interacted with a robot for 4 weeks and above and 19.8% (38) indicated that they had interacted with a robot for 0-1 week.

**Table 4.18: Post-test Background on Robots**

		Frequency	%
Have ever interacted with a robot?	Yes	192	100.0%
If yes, for how long?	0-1 week	38	19.8%
	2-3 weeks	114	59.4%
	4 weeks and above	40	20.8%

The posttest findings on the impact of robotic activities are as presented in Table 4.19.

**Table 4.19: Posttest Findings on Impact of integration of Robotic Activities**

	To no extent	To a lower extent	To a moderate extent	To a great extent	To a very great extent
Did the exposure to the robotic car and robotic arm give you a better understanding of the science subjects you learn in class	6 (3.1%)	5 (2.6%)	21 (10.9%)	58 (30.2%)	102 (53.1%)
Did the exposure to the robotic car and robotic arm give you a better understanding of what to expect in the Engineering career	5 (2.6%)	4 (2.1%)	17 (8.9%)	48 (25.0%)	118 (61.5%)
In your own opinion, to what extent has the exposure to Engineering through robotic activities changed the interest in Physics and Mathematics	3 (1.6%)	7 (3.6%)	17 (8.9%)	47 (24.5%)	118 (61.5%)
The use of robotic activities in learning of Physics and Mathematics changed improved my attitude towards the subjects	2 (1.0%)	3 (1.6%)	8 (4.2%)	79 (41.1%)	100 (52.1%)
The use of robotic activities should be introduced in the curriculum to improve students attitudes in Physics and Mathematics	2 (1.0%)	5 (2.6%)	1 (0.5%)	62 (32.3%)	122 (63.5%)

The post exposure opinion on whether exposure to the robotic car and robotic arm gave the respondents a better understanding of the science subjects learnt in class had 53.1% (102) of the respondents indicate to a very great extent, 30.2% (58) to a great extent, 10.9% (21) to a moderate extent, 3.1% (6) to no extent and 2.6% (5) to a lower extent. It is also clear that 61.5% (118), 25.0% (48), 8.9% (17), 2.6% (5) and 2.1% (4) of the participants indicated that exposure to the robotic car and robotic arm gave them a better understanding of what to expect in the Engineering career to a very great extent, to a great extent, to a moderate extent, to no extent and to a lower extent

respectively. The opinion of 61.5% (118), 24.5% (47), 8.9% (17), 3.6% (7) and 1.6% (3) of the respondents was that exposure to Engineering through robotic activities changed their interest in Physics and Mathematics to a very great extent, to a great extent, to a moderate extent, to a lower extent and to no extent respectively.

Majority of the respondents, a total of 93.2% (179) were of the opinion that the use of robotic activities in learning of Physics and Mathematics changed and improved their attitude towards the subjects to a great extent and to a very great extent; 4.2% (8), 1.6% (3) and 1.0% (2) indicated that use of robotic activities improved their attitude towards Physics and Mathematics to a moderate extent, to a lower extent and to no extent respectively. According to 95.8% (184) of the respondents, the use of robotic activities should be introduced in the curriculum to improve students' attitude in Physics and Mathematics to a great extent and to a very great extent.

The posttest findings on the career choice responses are as shown in Table 4.20.

**Table 4.20: Posttest Career Interest**

		Frequency	%
In which class or form did you start thinking about your career pathways	Primary	47	24.5%
	Form 1	49	25.5%
	Form 2	96	50.0%
I would like to be a scientist when I leave school	No	7	3.6%
	Not sure	30	15.6%
	Yes	155	80.7%
Physics and Mathematics are important to me as I prepare for my future career	No	2	1.0%
	Not sure	29	15.1%
	Yes	161	83.9%
I will select Physics as part of my subjects combination at the end of Form 2 level	No	2	1.0%
	Not sure	28	14.0%
	Yes	162	84.4%
Indicate the course you would want to pursue after doing your KCSE	Art related course	9	4.7%
	Pure and applied sciences course	12	6.2%
	Engineering course	152	79.2%
	Health sciences course	15	7.8%
	Any other	4	2.1%

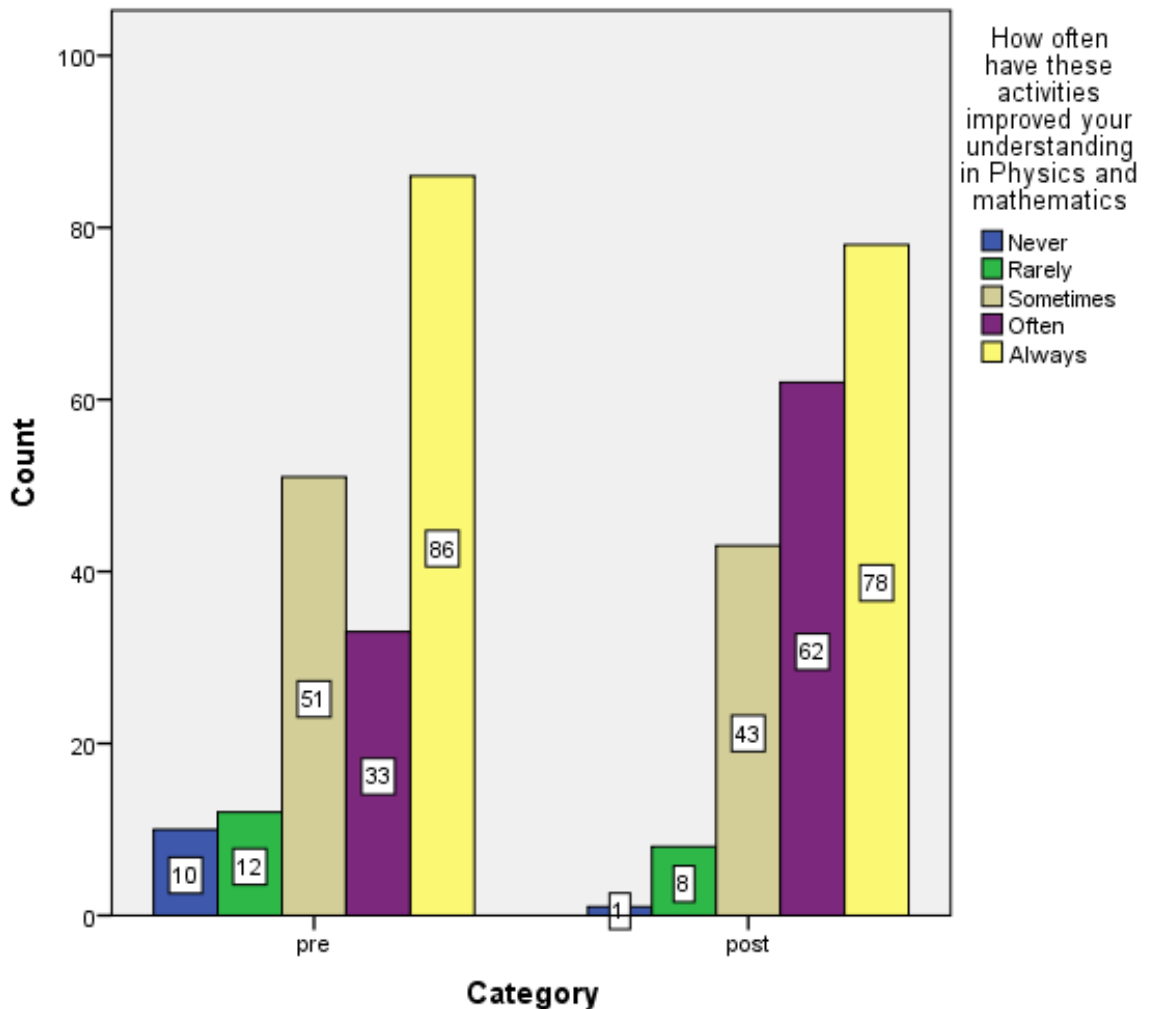


According to the results, 24.5% (47) of the respondents started thinking about their career pathways in Primary school, 25.5% (49) started thinking about their career pathways in Form 1 while 50.0% (96) started thinking about their career pathways while in Form 2. Post exposure to the educational robot had majority of the respondents, 80.7% (155), want to be scientists after completing Form 4, 15.6% (30) were not sure of whether they would want to be scientists after completing Form 4 while 3.6% (7) would not want to be scientists after completing Form 4. From the results, 83.9% (161) of the respondents' view Physics and Mathematics as important to them as they prepared for their future career, 15.1% (29) were not sure whether Physics and Mathematics are important to them as they prepared for their future career and 1.0% (2) indicated that Physics and Mathematics were not important to them as they prepared for their future career. On whether students would select Physics as their career choice, 84.4% (162) indicated that they would select, 14.0% (28) were not sure whether they would select Physics and 1.0% (2) would not select Physics at the end of their Form 2 level.

On the career interest that students wanted to pursue on completing their final exams in secondary schools, 79.2% (152) indicated that they would want to pursue a course related to Engineering, 7.8% (15) indicated that they would want to pursue a course related to health sciences, 6.2% (12) indicated that they would want to pursue a course related to pure and applied sciences, 4.7% (9) indicated that they would pursue an art related course while 2.1% (4) indicated they would pursue any other course not listed in the questionnaire.

#### 4.8 The Impact of the Robotic activities to the Form 2 Students

From the quantitative analysis, it is evident that differences in responses exist between the pretest and posttest responses. For instance, the responses on how often the responses perceived the activities aided in the improvement in their understanding of Physics and Mathematics as shown in Figure 4.11.



**Figure 4.11: Learners' Perception of how Robotic Activities Improved Understanding of the Subjects**

However, it cannot be concluded whether the differences are statistically significant or not based on the descriptive statistics only. As a result, inferential statistics, especially the paired sample t-test, sign test, one-way ANOVA and the Chi-Square tests, were used in assessing the significance of these differing responses. The

inferential test statistics were categorized as per the categories of the questionnaire items.

According to Ali and Bhaskar (2016), the sign test is a non-parametric test used in comparing two groups. It is an alternative to the paired sample t-test and is preferred when the distribution that exists for the differences of the paired observations is unknown. In this case, it is preferred because the observations cannot (or several sub-variables) be aggregated into one continuous variable. It is applied when the respondents are tested at two points in time or under two conditions that are different on the same variable. The test utilizes the + and – signs in a before and after study with the null hypothesis being set to have the + and – signs to be equal (equivalent to equal means in a paired sample t-test).

From the sign test conducted on the pretest and posttest responses on background on Physics and Mathematics, it is evident that the educational robot activities significantly improved the students' understanding in Physics and Mathematics ( $p\text{-value} < 0.0001$ ). However, on fun perception of Physics and Mathematics, there was no significant change ( $p\text{-value} = 0.762$ ); in fact, the pretest Likert scale responses had higher ratings as compared to the posttest Likert scale responses (negative differences=51 compared to positive differences=47 with 94 ties in students ranking on the Likert scale responses). Similarly, there was no significant change in Likert scale ratings for the pretest and posttest responses on how often the robotic activities improved students' understanding of Physics and Mathematics (Negative differences=53, positive differences=65, ties=74) (see Table 4.21).

**Table 4.21: Sign Test on Background on Physics and Mathematics**

		N	Z	Asymp. Sig (2-tailed)
How often are Physics and Mathematics fun? - How often are Physics and Mathematics classes fun?	Negative Differences <sup>a,d,g</sup>	51	-.303	.762
	Positive Differences <sup>b,e,h</sup>	47		
	Ties <sup>c,f,i</sup>	94		
	Total	192		
How often have these activities improved your understanding in Physics and Mathematics - How often have you engaged in activities that aid understanding Physics and Mathematics	Negative Differences <sup>a,d,g</sup>	51	-3.488	.000
	Positive Differences <sup>b,e,h</sup>	94		
	Ties <sup>c,f,i</sup>	47		
	Total	192		
How often have these activities improved your understanding in Physics and Mathematics - How often have these activities improved your understanding in Physics and Mathematics	Negative Differences <sup>a,d,g</sup>	53	-1.013	.311
	Positive Differences <sup>b,e,h</sup>	65		
	Ties <sup>c,f,i</sup>	74		
	Total	192		

The impact of robotic activities on better understanding of the science subjects learnt in class, what to expect in the Engineering career and on perception of Physics and Mathematics was evaluated using the paired Sample t-test. Paired samples t-test involves a comparison of the means between two groups that are related on the same dependent variable that is continuous. It can be used to test differences in the means of paired measurements such as those taken at two times that are different, for instance a pre-test and a post-test score where an intervention has been administered between the two points in time. The paired samples t-test test the null hypothesis that the two population means that are paired are equal (Xu *et al.*, 2017). In this study, a paired

samples t-test was applied for the categorical sub-variables with the same scale of measurement and measured one major aspect of the study; as a result, the sub-variables would be aggregated into one variable using a measure of central tendency.

From the descriptive statistics, it is evident that there are differences in opinions of the respondents on the three items-understanding of the science subjects learnt in class, understanding of what to expect in the Engineering career and perception of Physics and Mathematics-between the pretest and posttest responses. However, the significance of these difference is not evaluated, thus the paired sample t-test in this section. Prior to running the paired sample t-test, the pretest responses were aggregated into one variable, the pre-impact, while the post responses were aggregated into one variable, the post impact through the use of the mean. The paired sample t-test was then conducted. From the summary presented in Table 4.22, it is evident that the overall pretest impact had a mean of 3.0486 (approximately to a moderate extent) while the posttest impact had a mean of 4.3628 (approximately to a great extent).

**Table 4.22: Pre-Impact and Post-Test Impact Means**

		Mean	N	Std. Deviation	Std. Error Mean
Pair 1	Pre-impact	3.0486	192	.75732	.05466
	Post-impact	4.3628	192	.69130	.04989

The correlation between the two is significantly weak, ( $\rho = 0.424$ ,  $p\text{-value} < 0.0001$ ) as shown in Table 4.23.

**Table 4.23: Correlation between Pre-Impact and Post-Impact**

		N	Correlation	Sig.
Pair 1	Pre-impact & post-impact	192	.424	.000

The paired sample t-test results in Table 4.23 show that the  $p\text{-value} < 0.0001$  (t-statistic=-23.363). This is a clear indication that the difference between the overall

impact in the pretest responses and posttest responses is significant. The fact that that the posttest overall mean is higher than the pretest overall mean is a clear indication that the educational robot had an impact on understanding of science related subjects, understanding of what to expect in Engineering and perception of Physics and Mathematics.

**Table 4.24: Paired Sample t-test on Impact**

		Paired Differences					t	df	Sig. (2-tailed)
		Mean	Std. Deviation	Std. Error Mean	95% Confidence Interval of the Difference				
					Lower	Upper			
Pair 1	Pre-impact – post-impact	-1.31424	.77945	.05625	-1.42519	-1.20328	-23.363	191	.000

Paired sample t-test was used in assessing if there were significant changes on the career choice of the students after the introduction of the educational robot. Two new variables were computed using SPSS, pre-career choice (which was the mean of pretest responses on “I would like to be a scientist when I leave school” and “Physics and Mathematics are important to me as I prepare for my future career”) and post-career choice (which was the mean of posttest responses on “I would like to be a scientist when I leave school” and “Physics and Mathematics are important to me as I prepare for my future career”). Paired sample t-test was then carried to assess whether there was a significant difference between the posttest mean and pretest mean of the new variables. This helped in evaluating whether the introduction of educational robots had a significant effect on the career pathways of the students being alienated towards science and Engineering.

From the paired sample statistics shown Table 4.25, pre-career choice mean was 2.125 while the post-career choice mean was 2.7995.

**Table 4.25: Pre-Career Interest and Post-Career Interest Means**

		Mean	N	Std. Deviation	Std. Error Mean
Pair 1	Pre-career choice	2.1250	192	.44013	.03176
	Post-career choice	2.7995	192	.30295	.02186

The correlation results between the two variables (Table 4.26) was weak positive correlation, which was significant ( $\rho = 0.189$ ,  $p\text{-value}=0.009$ ).

**Table 4.26: Correlation between Pre-Career and Post-Career Interest**

		N	Correlation	Sig.
Pair 1	Pre-career choice & post-career choice	192	.189	.009

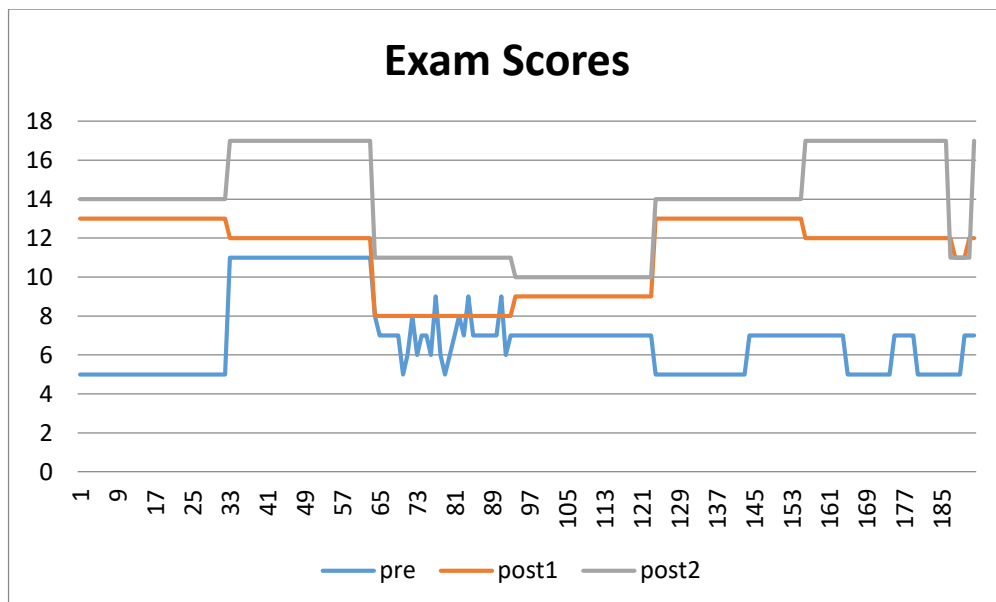
Though it can be observed that the two means are different, paired sample t-test was used to ascertain whether the difference was statistically significant. From the results in Table 4.27, the difference between the pre-test and post-test career choice is significant ( $p\text{-value} < 0.0001$ ). The finding that the post-test findings have a significantly higher mean implies that the educational robot had an effect on the career choice of students.

**Table 4. 27: Paired Sample t-test on Pre-Career and Post-Career Interest**

		Paired Differences					T	df	Sig. (2-tailed)
		Mean	Std. Deviation	Std. Error Mean	95% Confidence Interval of the Difference				
					Lower	Upper			
Pair 1	Pre-career choice – post-career choice	-.67448	.48488	.03499	-.74350	-.60546	-19.275	191	.000

The impact of robotic activities was also assessed through performance in three exams: a pre-exam that was given before exposure to the educational robot, a first post-exam that was given to the learners after briefly exposing them to the robots for a period of

one week and a second post-exam that was given to the learners after the entire process of exposing them to the educational robots. Testing the performance through exams was necessary to avoid misinterpretation of questionnaire responses that would be out of the learner's excitement upon seeing the robots. A line plot of the three exams that were administered depicts better performance for the second posttest exam after full exposure to the educational robot as compared to the first posttest exam and pretest exam in that order (see Figure 4.12).



**Figure 4.12: Line Plot of the Exam Scores**

The significance of the difference in exam scores was assessed through one-way ANOVA analysis. The one-way ANOVA is applied in comparing the means of more than two groups that are independent to determine whether the population means are equal or not. The null hypothesis of the one-way ANOVA tests the null hypothesis that all the population means under consideration are equal. The test statistic under one-way ANOVA demonstrates whether there is significance in the overall model, that is, whether a significant difference exists between any of groups under



consideration. However, it does not indicate which groups have significantly different means. Therefore, a post hoc test was used to assess which group pairs were significantly different (Kim, 2017).

From the results, the mean exam scores (scores rated out of 20) were pre-exam (score at No Exposure) mean score was 7.4797, the first pre-exam (score after brief exposure) mean score was 10.5528 and the second pre-exam (score after detailed exposure) mean score was 13.0488 (see Table 28).

**Table 4.28: Mean Exam Score**

	N	No Exposure	Brief Exposure	Detailed Exposure
Mean Exam Score	192	7.4797	10.5528	13.0488
Means for groups in homogeneous subsets are displayed.				
Uses Harmonic Mean Sample Size = 192.000.				

From the ANOVA analysis shown in Table 4.28, it is evident that the mean exam scores were significantly different,  $F_{2, 573} = 265.352$  with  $p\text{-value} < 0.0001$ . This is evident that exposure to the educational robots had a significant effect on performance of the learners and that the questionnaire responses on the impact of the educational robot were not due to excitement of the learners owing to seeing a robot.

**Table 4.29: One-Way ANOVA of Difference in Exam Scores**

	Sum of Squares	Df	Mean Square	F	Sig.
Between Groups	1914.249	2	957.125	265.352	.000
Within Groups	2066.813	573	3.607		
Total	3981.062	575			

The multiple comparisons results shown in Table 4.29 show that mean exam scores were significantly different among the three groups, all the  $p\text{-values} < 0.0001$ . This implies that even after being briefly exposed to the educational robot after one week, the performance significantly improved as compared to when the learners had not been

exposed to the educational robot. Similarly, performance significantly improved after the learners had been fully exposed to the educational robot as compared to when they had not been exposed and being exposed for one week.

**Table 4.30: Multiple Comparisons of Mean Exam Scores among Experimental Groups**

(I) Status of exposure to robots	(J) Status of exposure to robots	Mean Difference (I-J)	Std. Error	Sig.	95% Confidence Interval	
					Lower Bound	Upper Bound
No Exposure	Brief Exposure	-3.07317*	.30302	.000	-3.7863	-2.3601
	Detailed Exposure	-5.56911*	.30302	.000	-6.2822	-4.8560
Brief Exposure	No Exposure	3.07317*	.30302	.000	2.3601	3.7863
	Detailed Exposure	-2.49593*	.30302	.000	-3.2090	-1.7828
Detailed Exposure	No Exposure	5.56911*	.30302	.000	4.8560	6.2822
	Brief Exposure	2.49593*	.30302	.000	1.7828	3.2090

\*. The mean difference is significant at the 0.05 level.

Further analysis was conducted to test the difference in mean exam scores between boys and girls as shown in Table 4.31. The significance of these differences was tested through independent samples t-test.

**Table 4.31: Mean Exam Score across Gender**

	Gender of Participant	N	Mean	Std. Deviation	Std. Error Mean
Pre-Exam Score	Male	104	7.3462	2.56855	.25187
	Female	88	6.3523	.98307	.10480
Post-Exam Score 1	Male	104	11.4904	1.81683	.17816
	Female	88	10.9091	1.99215	.21236
Post-Exam Score 2	Male	104	14.8942	2.36035	.23145
	Female	88	12.5341	2.43513	.25959

From the group statistics results, the mean score in the pre-test exam was 7.3462 for boys and 6.3523 for girls; the mean score for the first post-test exam (after one-week exposure to the educational robot) was 11.4904 and 10.9091 for boys and girls

respectively while the mean score in the second post-exam (after full exposure to the educational robot) was 14.8942 and 12.5341 for boys and girls respectively.

Though the means are different, independent samples t-test was used to test whether the differences were significantly different. For the pre-test (before exposure to the robots) and the first post-test exam (after one-week exposure) the mean exam scores between boys and girls were significantly different; t-value = 3.423 & p-value < 0.0001 for pre-test exam and t-value = 2.113 & p-value < 0.0001 for the first post-test exam score. However, the means are not significantly different for the second post-test exam, t-value = 6.804, p-value = 0.456 > 0.05 (see Table 4.31). This shows that there was significant improvement after exposure to the robot to an extent that no significant differences were observed across boys and girls.

**Table 4.32: Independent Samples t-test for difference in Means**

		Levene's Test for Equality of Variances		t-test for Equality of Means						
		F	Sig.	T	df	Sig. (2-tailed)	Mean Difference	Std. Error Difference	95% Confidence Interval of the Difference	
									Lower	Upper
Pre-Exam Score	Equal variances assumed	113.510	.000	3.423	190	.001	.99388	.29037	.42112	1.56665
	Equal variances not assumed			3.643	136.892	.000	.99388	.27280	.45444	1.53333
Post-Exam Score 1	Equal variances assumed	13.261	.000	2.113	190	.036	.58129	.27507	.03871	1.12388
	Equal variances not assumed			2.097	178.057	.037	.58129	.27720	.03428	1.12831
Post-Exam Score 2	Equal variances assumed	.559	.456	6.804	190	.000	2.36014	.34688	1.67591	3.04437
	Equal variances not assumed			6.786	182.753	.000	2.36014	.34778	1.67395	3.04633

Further analysis was conducted on differences in exam scores across the school categories. Since the school categories were three: boys, girls and mixed secondary schools, one-way ANOVA was used in evaluating whether the exam scores were significantly different. The descriptive statistics below show that the mean score in the pre-test exam was 6.1556, 7.3396 and 6.9894 for girls, boys and mixed secondary schools respectively; the mean score in the first post-test exam was 12.0222, 10.4151 and 11.2979 for girls, boys and mixed secondary schools respectively; the mean score in the second post-test exam score was 13.8889, 14.6226 and 13.3191 for girls, boys and mixed secondary schools respectively (see Table 4.33).

**Table 4.33: Descriptive Statistics of Exam Scores across School Categories**

		N	Mean	Std. Deviation	Std. Error	95% Confidence Interval for Mean		Minimum	Maximum
						Lower Bound	Upper Bound		
Pre-Exam Score	Girls School	45	6.1556	.99899	.14892	5.8554	6.4557	5.00	7.00
	Boys School	53	7.3396	2.15677	.29626	6.7451	7.9341	5.00	11.00
	Mixed School	94	6.9894	2.29302	.23651	6.5197	7.4590	5.00	11.00
	Total	192	6.8906	2.06022	.14868	6.5974	7.1839	5.00	11.00
Post-Exam Score 1	Girls School	45	12.0222	1.40598	.20959	11.5998	12.4446	8.00	13.00
	Boys School	53	10.4151	1.97517	.27131	9.8707	10.9595	8.00	12.00
	Mixed School	94	11.2979	1.93346	.19942	10.9019	11.6939	8.00	13.00
	Total	192	11.2240	1.91627	.13829	10.9512	11.4967	8.00	13.00
Post-Exam Score 2	Girls School	45	13.8889	2.29844	.34263	13.1984	14.5794	10.00	17.00
	Boys School	53	14.6226	2.96276	.40697	13.8060	15.4393	11.00	17.00
	Mixed School	94	13.3191	2.55777	.26381	12.7953	13.8430	10.00	17.00
	Total	192	13.8125	2.66375	.19224	13.4333	14.1917	10.00	17.00

Though differences in mean exam scores can be observed across the different school categories, the significance of these differences was tested through ANOVA analysis. For the first exam, the mean exam scores were significantly different across the three school categories,  $F_{2, 189} = 4.381$  and  $p\text{-value} = 0.014 < 0.05$ . Similarly, the mean exam scores were significantly different for the first post-test exam ( $F_{2, 189} = 9.467$ ,  $p\text{-value} < 0.0001$ ) and for the second post-test exam ( $F_{2, 189} = 4.220$ ,  $p\text{-value} = 0.016 < 0.005$ ) (see Table 4.34).

**Table 4.34: ANOVA Analysis of Difference in Exam Scores across School Categories**

		Sum of Squares	df	Mean Square	F	Sig.
Pre-Exam Score	Between Groups	35.916	2	17.958	4.381	.014
	Within Groups	774.787	189	4.099		
	Total	810.703	191			
Post-Exam Score 1	Between Groups	63.865	2	31.932	9.467	.000
	Within Groups	637.505	189	3.373		
	Total	701.370	191			
Post-Exam Score 2	Between Groups	57.927	2	28.964	4.220	.016
	Within Groups	1297.323	189	6.864		
	Total	1355.250	191			

The multiple comparisons results revealed that there were significant differences in mean exam scores between girls' and boys' schools ( $p\text{-value} = 0.012 < 0.05$ ) in the pre-test exam. The findings also revealed that there was a significant difference in the mean exam scores between boys' and girls' secondary schools ( $p\text{-value} < 0.0001$ ) and boys and mixed secondary schools ( $p\text{-value} = 0.016 < 0.005$ ) for the first post-test exam. In the second post-test exam, there was a significant difference between boys and mixed secondary schools ( $p\text{-value} = 0.012 < 0.005$ ) (See Table 4.35).

**Table 4.35: Multiple Pairwise Comparison Test for Differences in Exam Scores among School Categories**

Dependent Variable	(I) School Category	(J) School Category	Mean Difference (I-J)	Std. Error	Sig.	95% Confidence Interval	
						Lower Bound	Upper Bound
Pre-Exam Score	Girls School	Boys School	-1.18407*	.41042	.012	-2.1536	-.2145
		Mixed School	-.83381	.36703	.062	-1.7008	.0332
	Boys School	Girls School	1.18407*	.41042	.012	.2145	2.1536
		Mixed School	.35026	.34779	.573	-.4713	1.1719
	Mixed School	Girls School	.83381	.36703	.062	-.0332	1.7008
		Boys School	-.35026	.34779	.573	-1.1719	.4713
Post-Exam Score 1	Girls School	Boys School	1.60713*	.37229	.000	.7277	2.4866
		Mixed School	.72435	.33293	.078	-.0621	1.5108
	Boys School	Girls School	-1.60713*	.37229	.000	-2.4866	-.7277
		Mixed School	-.88278*	.31548	.016	-1.6280	-.1375
	Mixed School	Girls School	-.72435	.33293	.078	-1.5108	.0621
		Boys School	.88278*	.31548	.016	.1375	1.6280
Post-Exam Score 2	Girls School	Boys School	-.73375	.53108	.353	-1.9883	.5208
		Mixed School	.56974	.47493	.455	-.5522	1.6917
	Boys School	Girls School	.73375	.53108	.353	-.5208	1.9883
		Mixed School	1.30349*	.45004	.012	.2404	2.3666
	Mixed School	Girls School	-.56974	.47493	.455	-1.6917	.5522
		Boys School	-1.30349*	.45004	.012	-2.3666	-.2404

\* The mean difference is significant at the 0.05 level.

Follow-up observations were done to verify whether those learners who had indicated that they would select Physics at the end of their Form 2 level actually did so. In this

study, a follow-up was conducted on the same learners after they had selected subjects during their learning in Form three and those who had selected Physics recorded. The aim was to see whether there was any significant decline on those who had indicated that they would select Physics after being exposed to the educational and those who actually selected. The study expected significant association between the two. Therefore, cross-tabulation and Chi-Square test were used in assessing this relationship. From the cross-tabulation findings in Table 4.36, 76.0% (146) of the learners actually selected Physics at the end of their Form Two. Table 4.35 also showed that, out of those students who had indicated in the questionnaires that they would select Physics as part of their subjects' combination at the end of their Form Two level, 87.0% (141) actually selected Physics. This is an indication that the decline may not have been so big.

**Table 4.36: Cross-Tabulation Results on Actual versus Expected Physics Selection**

			I will select Physics as part of my subjects combination at the end of Form 2 level			Total
			No	Not Sure	Yes	
Post Experiment follow-up on whether learners selected Physics at the end of Form 2	Yes	Count	0	5	141	146
		% within I will select Physics as part of my subjects combination at the end of Form 2 level	0.0%	17.9%	87.0%	76.0%
	No	Count	2	23	21	46
		% within I will select Physics as part of my subjects combination at the end of Form 2 level	100.0%	82.1%	13.0%	24.0%
Total		Count	2	28	162	192
		% within I will select Physics as part of my subjects combination at the end of Form 2 level	100.0%	100.0%	100.0%	100.0%



Chi-Square test was used to test whether there was any significant association between those learners who had indicated that they would select Physics at the end of their Form Two and those who actually selected Physics. The aim was to test if the questionnaire responses would have resulted from excitement due to exposure to the educational robots. A Chi-Square test evaluates whether an association exists between two variables that are categorical. The test utilizes cross tabulation with the categories of one variable appearing in the rows while the other variables' categories appearing in the columns. The chi-square test is not appropriate if the study's categorical variables represent observations of 'pre-test' and 'post-test' nature; the assumption of independence in observations is violated (Rana & Singhal, 2015).

From the results presented in Table 4.37, there was a significant association between actual Physics selection (follow-up observations) and expected selection (post-test responses); an indication that the actual selection was as expected from the questionnaire responses.

**Table 4.37: Chi-Square Test on Actual and Expected Physics Selection**

	Value	df	Asymp. Sig. (2-sided)
Pearson Chi-Square	69.130 <sup>a</sup>	2	.000
Likelihood Ratio	60.193	2	.000
Linear-by-Linear Association	66.553	1	.000
N of Valid Cases	192		
a. 2 cells (33.3%) have expected count less than 5. The minimum expected count is .48.			

From the inferential statistics, it was evident that robotic activities improved the learners' understanding of Physics and Mathematics. The paired samples t-test also showed that integration of robotic activities significantly improved learning, creativity, attitude and perception on the need to have robots in teaching Physics and

Mathematics. The findings also showed that the educational robot had a significant impact on understanding of science related subjects, understanding of what to expect in Engineering and perception of Physics and Mathematics. From the findings on the career choice, a significant difference was observed between the pre-test and post-test career choices of the learners. The posttest findings demonstrated that the educational robot had an effect on the learners in selecting STEM oriented careers.

The findings that educational robots had an influence in understanding of Physics and Mathematics agreed with Tiryaki and Adguzel (2021) who conducted a study in Turkey. From the study educational robots' utilization in teaching STEM increased learners' attitude and creativity which are key in their understanding of the subjects. The study by Tiryaki and Adguzel (2021) also support the findings that robots increase learners' interest and orientation towards STEM related careers. This is achieved through exposing learners to real-life and daily life based problems that are STEM oriented; making learners feel like scientists which in turn has a significant effect on their career choices in the future. These findings are also in tandem with Doerschuk *et al.*, (2016) who claimed that educational robots provide an opportunity for hands-on learning which positively impacts learners' interest and career advancement towards STEM oriented fields.

The findings of the study also posted higher means for the post-test responses on STEM career choice and overall impact of the educational robot. Similar findings were found by Chen and Chang (2018) who found significant differences between two groups, one with a locally assembled robot and the other with a bought robot. The locally assembled robot had a higher mean score on the learners' career orientation as compared to the bought robot. If a robot is assembled in a manner that learners can

easily relate with and conceptualize, it is highly likely that when it is integrated in STEM curriculum that it will significantly affect their interest in STEM related subjects and career orientation towards STEM courses (Chen & Chang, 2018).

The findings that more students were aligned towards STEM related courses after being exposed to the educational robot aligned with Goh and Ali (2014). Just like in this study, Goh and Ali (2014) conducted a paired analysis between pre-test and post-test responses and found higher posttest means as compared to the pre-test under the STEM Career Interest Scale. This meant that, after the students were exposed to the educational robot, they developed an increased understanding, conceptualization, interest and beliefs in STEM related subjects leading to aspirations that were positive towards STEM related courses.

Prior to being exposed to educational robots, it can be argued that learners tend to have views that are inaccurate of who engineers and scientists are and what they actually do. This would negatively affect their interest in Engineering and science related careers. The fact that pretest findings of this study have less learners showing interest in STEM related career choices as compared to the posttest findings clearly demonstrates that exposure to educational robots leads to positive impact on the perception and understanding all about what Engineering and science related careers are and what they do. This improves their career orientation towards STEM (Hammack *et al.*, 2015).

#### **4.9 Summary**

In this study, low cost robotic car and arm have been achieved, which are suitable for development of robotic activities and also as teaching aids. Robotic activities were developed and integrated to Physics and mathematics topics. The integrated robotics

activities were suitable and relevant in teaching and learning of the Physics and mathematics topics as drawn from both students' and teachers' responses.

The overall response rate in this study was 72.1%. Data analysis was done with the help of SPSS and Microsoft excel. Quantitative data was analyzed using descriptive statistics and inferential statistics. Results from this study show that the exposure of the Form 2 students to robots and robotic activities had significant effect on the perception of Physics and mathematics subjects. The robotics activities enhanced learning of the subjects and the students developed positive attitudes towards the subjects.

The exposure also had a significant impact on the learners' interest in Engineering career pathways as depicted by the choice of subject combination towards these careers. The actual selection of subject combination was established through a follow up observation carried out six months after the completion of the workshops. The observation revealed that there was a significant association between actual Physics selection (follow-up observations) and expected selection (post-test responses) which is indication that the actual selection was as expected from the questionnaire responses.

## CHAPTER FIVE

### SUMMARY, CONCLUSION AND RECOMMENDATIONS

#### 5.1 Summary of Major Findings

The study sought to fabricate robot car and arm for secondary school STEM educational purposes, develop robotic activities for integration to Physics and Mathematics based on the robots fabricated, examine the effect of the integrated developed robotic activities to perception of secondary school STEM subjects and assess the impact of the robotic activities to form 2 secondary students on their interest towards Engineering career pathways.

The first objective dealt with the fabrication and assembly of robotic car and arm for educational purposes. In this study the robots were fabricated for educational purposes, with features such as low cost, simplicity, portability, and flexibility. The construction utilized locally available materials such as plastic sheets, readily available circuits and sensors, easy to install motors, medium sized wheels. For the robotic design, Arduino Uno programming was used and a Raspberry pi microcomputer was utilized to add some video capabilities. The robotic car was designed with line following functions realized through infra-red sensors and obstacle avoidance functions realized through the ultrasonic sensor.

The second objective was on the development of the robotic activities for integration to Physics and Mathematics. Different activities were developed and integrated to subjects based on the fabricated robots. These activities included basic technical drawing, 3-D printing, basic electronics, solar photovoltaic, robot part identification and assembly, basic programming, line following, obstacle avoidance, and robotic arm rotational dynamics activities. Basic technical drawing involved tasks such as drawing

2-D shapes and extruding the shapes to obtain 3-D models; 3-D printing involved printing of the 3-D shapes developed; basic electronics activities involved tasks such as taking measurements of basic electrical quantities such as resistance, electric current, voltage and power; solar photovoltaic activities involved measurement of the components of solar energy and tasks on various applications of solar energy. On the other hand, robot part identification and assembly involved identification of various components of the robotic kit such as sensors, transducers, motors, microcontrollers amongst others; while basic programming involved programming of the robot parts majorly the sensors and motors.

Line following activities involved tasks such as creation of different paths with varying shapes and colours, linear motion tasks and tasks involving determination of area, perimeter and circumference. Obstacle avoidance activities involved tasks such as waves' reflection and distance from obstacle calculations while robotic arm rotational dynamics activities involved tasks such as reflection, rotation, effects of force, angular and circular motion and tasks involving conceptualization of 3-D concepts.

The integration of the developed activities to Physics and Mathematics topics was achieved based on four themes: interdisciplinary, adaptability, interest and problem solving themes. The interdisciplinary theme enabled integration of the activities developed in both Physics and Mathematics and comprised of activities such as technical drawing, line following, basic programming, obstacle avoidance, and robotic arm rotational dynamic activities. The adaptability theme enabled integration into topics such as measurements, basic electricity, geometry, angles, rotation and motion and incorporated activities such as basic electronics, basic programming, and robotic

arm rotational dynamics activities. Interest theme was to stimulate the learners' interest in the topics integrated and also made concepts that were abstract easier and involved activities such as robot part identification, line following, obstacle avoidance and robotic arm rotational dynamics activities. Lastly, problem solving theme (individual and group) enabled the users to work individually and in groups and activities such as basic electronics, basic programming, robot part identification, line following, obstacle avoidance and robotic arm rotational dynamics activities. The third objective examined the effect of exposing the learners to the integrated developed robotic activities on their perception of Physics and Mathematics. From the quantitative analysis, it is evident that differences in responses exist between the pretest and posttest responses. The effect of exposure of the learners to the integrated robotic activities were assessed on their significance in improving students' opinion on understanding, fun, creativity, motivation, interest and perception of the subjects with the paired sample t-test indicating significance effect with  $p\text{-value} < 0.0001$ .

The fourth objective assessed the impact of robotic activities on students' decision to choose a subject combination towards an Engineering career pathways. From the quantitative analysis, it is evident that differences in responses exist between the pretest and posttest responses. From the sign test, it was evident that the educational robot activities significantly improved the students' understanding in Physics and Mathematics ( $p\text{-value} < 0.0001$ ). Paired sample-test was used to test on the difference in the overall mean (for the pretest and posttest responses) of the items regarding the impact of the robotic kit designed. The paired sample t-test findings revealed significant ( $p\text{-value} < 0.0001$ ) differences between pretest and posttest means with the posttest mean being higher as compared to the pretest mean (posttest mean=4.3628,

pretest mean=3.0486). The paired sample t-test was used to evaluate whether the pre-career choice mean was significantly different from the post career choice mean, with the results indicating significant differences (p-value<0.0001) with the post-career choice mean (2.7995) being higher than the pre-career choice mean (2.1250). From the career choices listed by the students, it was evident that more students preferred Engineering-oriented careers after being exposed to the robotic kit. Through Chi-Square test, a significant association was found between the learners who had indicated that they would select Physics at the end of their Form Two and those who actually selected the subject. This is an indication that the questionnaire responses were not out of excitement due to being exposed to the educational robots.

## **5.2 Conclusion**

Based on the findings of the study, the following conclusions can be made:

- i) That the fabrication of the robotic car and arm for secondary school educational purposes should deviate from conventional designs that are expensive by adopting locally available materials and readily available programmes that are simple to understand and modify. This will ensure that low cost, flexible and easy to use robots are available thus opening up utilization of robotics to education.
- ii) That development of precollege robotic activities based on the designed kit should be based on tasks that are simple and easy to understand. This will enhance modification and understanding of the basic operations of the robotic kit by the learners.



- iii) That integration of robotic activities in Physics and Mathematics should be based on themes that enhance creativity, innovation and excite learners while being taught different topics.
- iv) That the robotic activities developed have a significant impact on students' interest in Engineering career pathways. Secondary schools should strive to incorporate educational robotics during the regular lessons. This current study concludes that the use of robotics activities can positively impact student interest in STEM subjects and careers.

### **5.3 Recommendations**

Based on the findings educational robotics had an effect on students' understanding, interest, motivation, fun and orientation towards an Engineering career pathways. Additionally, the robotics is significant in making learning more of learner centered rather than teacher/instructor driven.

#### **5.3.1 Recommendations for policy**

As a result of the findings drawn from this study, the government should facilitate the integration of educational robots in the current STEM curriculum. This can be achieved through;

- i. Policy makers in education, the curriculum should be reviewed so as to adopt educational robots as a teaching/learning tool and teachers/instructors retrained on robotic use in education.
- ii. Stakeholder in education which includes and not limited to Schools, Ministry of Education Science and technology (MOEST), Kenya Institute of Curriculum Development(KICD) among others.

### **5.3.2 Recommendations for Further Studies**

The current study involved one cohort of students with no distinction between experimental and control groups. The study proposes the following suggestion for further studies:

- i. Future studies should be conducted involving two distinct groups, one comprising of a control group and the other one comprising of an experimental group.
- ii. Future studies should also be conducted on the applicability of educational robotics in other subjects such as Biology, Geography, Chemistry, Agriculture and in Arts related subjects.
- iii. The current study should be replicated in lower grades owing to the fact that the Kenyan curriculum is in transition from the traditional 8-4-4 system to the Competency Based Curriculum.

## REFERENCES

- Acharya, A. S., Prakash, A., Saxena, P., & Nigam, A. (2013). Sampling: Why and how of it. *Indian Journal of Medical Specialties*, 4(2), 330-333.
- Ackermann, E. (2001). Piaget's constructivism, Papert's constructionism: What's the difference. *Future of learning group publication*, 5(3), 438.
- Acut, D. (2021). *Linking Pre-College STEM Students to Science, Technology, and Engineering Industries Through a Work-Integrated Learning (WIL) Curriculum* (No. 6705). EasyChair.
- Afari, E., & Khine, M. S. (2017). Robotics as an educational tool: Impact of lego mindstorms. *International Journal of Information and Education Technology*, 7(6), 437-442.
- Ali, Z., & Bhaskar, S. B. (2016). Basic statistical tools in research and data analysis. *Indian journal of anaesthesia*, 60(9), 662.
- Alimisis, D. (2019). Teacher training in educational robotics: The ROBOESL Project paradigm. *Technology, Knowledge and Learning*, 24(2), 279-290.
- Altin, H., & Pedaste, M. (2013). Learning approaches to applying robotics in science education. *Journal of baltic science education*, 12(3), 365.
- Alvi, M. (2016). A manual for selecting sampling techniques in research. Retrieved from <https://mpira.ub.uni-muenchem.de70218/>
- Andrew, D. P., Pedersen, P. M., & McEvoy, C. D. (2019). *Research methods and design in sport management*. Human Kinetics.
- Angel-Fernandez, J. M., & Vincze, M. (2018, March). Engineers Designing and Implementing Activities for School Students: What Have We Learned? In *2018 IEEE World Engineering Education Conference (EDUNINE)* (pp. 1-6). IEEE.
- Antony, M., Parameswaran, M., Mathew, N., Sajithkumar, V. S., Joseph, J., & Jacob, C. M. (2020, June). Design and implementation of automatic guided vehicle for hospital application. In *2020 5th International Conference on Communication and Electronics Systems (ICCES)* (pp. 1031-1036). IEEE.
- Anwar, S., Bascou, N. A., Menekse, M., & Kardgar, A. (2019). A systematic review of studies on educational robotics. *Journal of Pre-College Engineering Education Research (J-PEER)*, 9(2), 2.
- Artal, R., & Rubinfeld, S. (2017). Ethical issues in research. *Best Practice & Research Clinical Obstetrics & Gynaecology*, 43, 107-114.
- Bagnall, B. (2014). *Maximum LEGO EV3: Building Robots with Java Brains*. Variant Press.
- Benitti, F. B. V., & Spolaôr, N. (2017). How have robots supported STEM teaching?. In *Robotics in STEM education* (pp. 103-129). Springer, Cham.

- Bryman, A. (2012). *Social research methods* (4<sup>th</sup> ed.). Oxford: Oxford University Press.
- Bybee, R. W. (2010). Advancing STEM education: A 2020 vision. *Technology and Engineering teacher*, 70(1), 30.
- Cano, S. (2022). A Methodological Approach to the Teaching STEM Skills in Latin America through Educational Robotics for School Teachers. *Electronics*, 11(3), 395.
- Carnevale, A. P., Smith, N., & Melton, M. (2011). STEM: Science Technology Engineering Mathematics. *Georgetown University Center on Education and the Workforce*.
- Chen, Y., & Chang, C. C. (2018). The impact of an integrated robotics STEM course with a sailboat topic on high school students' perceptions of integrative STEM, interest, and career orientation. *EURASIA Journal of Mathematics, Science and Technology Education*, 14(12), em1614.
- Chin, K. Y., Hong, Z. W., & Chen, Y. L. (2014). Impact of using an educational robot-based learning system on students' motivation in elementary education. *IEEE Transactions on learning technologies*, 7(4), 333-345.
- Ching, Y. H., Yang, D., Wang, S., Baek, Y., Swanson, S., & Chittoori, B. (2019). Elementary school student development of STEM attitudes and perceived learning in a STEM integrated robotics curriculum. *TechTrends*, 63(5), 590-601.
- Chomyim, C., Chaisanit, S., & Trangansri, A. (2015). Low Cost Mobile Robot Kits Design as a Teaching Tool for Education and Research. In *Applied Mechanics and Materials* (Vol. 752, pp. 1010-1015). Trans Tech Publications Ltd.
- Cook, T. D. (2015). Quasi-experimental design. *Wiley encyclopedia of management*, 1-2.
- Cochran, W.G. (1963). *Sampling Technique*. 2nd Edition, John Wiley and Sons Inc., New York.
- Correll, N., Wailes, C., & Slaby, S. (2014). A one-hour curriculum to engage middle school students in robotics and computer science using cubelets. In *Distributed Autonomous Robotic Systems* (pp. 165-176). Springer, Berlin, Heidelberg.
- Corrigan, O., & Tutton, R. (2006). What's in a name? Subjects, volunteers, participants and activists in clinical research. *Clinical Ethics*, 1(2), 101-104.
- Creswell, J. W. (2014). *A concise introduction to mixed methods research*. SAGE publications.
- Cross, J., Hamner, E., Zito, L., Nourbakhsh, I., & Bernstein, D. (2016, October). Development of an assessment for measuring middle school student attitudes towards robotics activities. In *2016 IEEE Frontiers in Education Conference (FIE)* (pp. 1-8). IEEE.

- Cummings, J. N. (2004). Work groups, structural diversity, and knowledge sharing in a global organization. *Management science*, 50(3), 352-364.
- D'Amico, A., Guastella, D., & Chella, A. (2020). A playful experiential learning system with educational robotics. *Frontiers in Robotics and AI*, 7, 33.
- DeCoito, I. (2016). STEM education in Canada: A knowledge synthesis. *Canadian Journal of Science, Mathematics and Technology Education*, 16(2), 114-128.
- Dikko, M. (2016). Establishing construct validity and reliability: Pilot testing of a qualitative interview for research in Takaful (Islamic insurance). *The qualitative report*, 21(3), 521-529.
- Doerschuk, P., Bahrim, C., Daniel, J., Kruger, J., Mann, J., & Martin, C. (2016). Closing the gaps and filling the STEM pipeline: A multidisciplinary approach. *Journal of Science Education and Technology*, 25(4), 682-695.
- Doody, O., & Noonan, M. (2013). Preparing and conducting interviews to collect data. *Nurse researcher*, 20(5).
- Eguchi, A. (2014, July). Robotics as a learning tool for educational transformation. In *Proceeding of 4th international workshop teaching robotics, teaching with robotics & 5th international conference robotics in education Padova (Italy)* (pp. 27-34).
- Eguchi, A. (2016). RoboCupJunior for promoting STEM education, 21st century skills, and technological advancement through robotics competition. *Robotics and Autonomous Systems*, 75, 692-699.
- Fantz, T. D., Siller, T. J., & Demiranda, M. A. (2011). Pre-collegiate factors influencing the self-efficacy of Engineering students. *Journal of Engineering Education*, 100(3), 604-623.
- Feijoo-Almonacid, A., & Rodriguez-Garavito, C. H. (2022). Hardware-Software Platform for the Development of STEM Skills. *IEEE Revista Iberoamericana de Tecnologías del Aprendizaje*, 17(2), 170-177.
- Firmin, R. L., Bonfils, K. A., Luther, L., Minor, K. S., & Salyers, M. P. (2017). Using text-analysis computer software and thematic analysis on the same qualitative data: A case example. *Qualitative Psychology*, 4(3), 201.
- Fitriyaningsih, R. N., Budiyanto, C. W., & Yuana, R. A. (2019, June). Behavioral patterns of vocational students in Lego Mindstorm: A literature review. In *AIP Conference Proceedings* (Vol. 2114, No. 1, p. 060003). AIP Publishing LLC.
- García-Saura, C., González-Gómez, J., & Saura, C. G. (2012). Low cost educational platform for robotics, using open-source 3d printers and open-source hardware. *ICERI2012 proceedings*, 2699-2706.
- Gibson, C. B., & Gibbs, J. L. (2006). Unpacking the concept of virtuality: The effects of geographic dispersion, electronic dependence, dynamic structure, and

- national diversity on team innovation. *Administrative science quarterly*, 51(3), 451-495.
- Gichuki, T. (2015). *African peace service corps on youth empowerment strategies*. Global peace foundation. Retrieved from <https://www.slideshare.net/mobile.dr>
- Gidron, Y. (2020). Reliability and validity. In *Encyclopedia of Behavioral Medicine* (pp. 1869-1870). Cham: Springer International Publishing.
- Goh, H., & Ali, M. B. (2014). Robotics as a tool to stem learning. *International Journal for Innovation Education and Research*, 2(10), 66-78.
- Gomez, R., Szapiro, D., Galindo, K., & Nakamura, K. (2018, March). " Haru": Hardware Design of an Experimental Tabletop Robot Assistant. In *2018 13th ACM/IEEE International Conference on Human-Robot Interaction (HRI)* (pp. 233-240). IEEE.
- Graven, O. H., & Samuelsen, D. A. (2011). Using Remote Laboratories in Combination with Hands-on Laboratories in an Analogue Electronics Module. *Using Remote Labs in Education*, 231.
- Gura, M. (2012). Lego Robotics: STEM Sport of the Mind. *Learning & Leading with Technology*, 40(1), 12-16.
- Hajkowicz, S. A., Reeson, A., Rudd, L., Bratanova, A., Hodgers, L., Mason, C., & Boughen, N. (2016). Tomorrow's digitally enabled workforce: Megatrends and scenarios for jobs and employment in Australia over the coming twenty years. *Australian Policy Online*.
- Hammack, R., Ivey, T. A., Utley, J., & High, K. A. (2015). Effect of an Engineering camp on students' perceptions of Engineering and technology. *Journal of Pre-College Engineering Education Research (J-PEER)*, 5(2), 2.
- Heilbronner, N. N. (2011). Stepping onto the STEM pathways: Factors affecting talented students' declaration of STEM majors in college. *Journal for the Education of the Gifted*, 34(6), 876-899.
- Hertzog, M. A. (2008). Considerations in determining sample size for pilot studies. *Research in nursing & health*, 31(2), 180-191.
- Hilton, C. E. (2017). The importance of pretesting questionnaires: a field research example of cognitive pretesting the Exercise Referral Quality of Life Scale (ER-QLS). *International Journal of Social Research Methodology*, 20(1), 21-34.
- Hmelo-Silver, C. E., Duncan, R. G., & Chinn, C. A. (2007). Scaffolding and achievement in problem-based and inquiry learning: a response to Kirschner, Sweller, and. *Educational psychologist*, 42(2), 99-107.

- International Society for Technology in Education (ISTE). (2017). *ISTE Standards for educators*. Retrieved November 17, 2019, from <https://www.iste.org/standards/for-educators>.
- Jung, S. E., & Won, E. S. (2018). Systematic review of research trends in robotics education for young children. *Sustainability, 10*(4), 905.
- Kaneoka, A. S., Langmore, S. E., Krisciunas, G. P., Field, K., Scheel, R., McNally, E., ... & Cabral, H. (2013). The Boston residue and clearance scale: preliminary reliability and validity testing. *Folia Phoniatria et Logopaedica, 65*(6), 312-317.
- Kazi, A. S., & Akhlaq, A. (2017). Factors Affecting Students' Career Choice. *Journal of Research & Reflections in Education (JRRE), 11*(2).
- Kelley, T. R., Knowles, J. G., Holland, J. D., & Han, J. (2020). Increasing high school teachers' self-efficacy for integrated STEM instruction through a collaborative community of practice. *International Journal of STEM Education, 7*(1), 1-13.
- Khanlari, A., & Mansourkiaie, F. (2015, July). Using robotics for STEM education in primary/elementary schools: Teachers' perceptions. In *2015 10th International Conference on Computer Science & Education (ICCSE)* (pp. 3-7). IEEE.
- Kim, C., Yuan, J., Kim, D., Doshi, P., Thai, C. N., Hill, R. B., & Melias, E. (2019). Studying the usability of an intervention to promote teachers' use of robotics in STEM education. *Journal of Educational Computing Research, 56*(8), 1179-1212.
- Kim, P. G., Park, C. G., Jong, Y. H., Mo, E. J., Kim, C. S., Jie, M. S., ... & Lee, K. W. (2007, August). Obstacle avoidance of a mobile robot using vision system and ultrasonic sensor. In *International Conference on Intelligent Computing* (pp. 545-553). Springer, Berlin, Heidelberg.
- Kim, T. K. (2017). Understanding one-way ANOVA using conceptual figures. *Korean journal of anesthesiology, 70*(1), 22-26.
- Kimberlin, C. L., & Winterstein, A. G. (2008). Validity and reliability of measurement instruments used in research. *American journal of health-system pharmacy, 65*(23), 2276-2284.
- Kirschner, P., Sweller, J., & Clark, R. E. (2006). Why unguided learning does not work: An analysis of the failure of discovery learning, problem-based learning, experiential learning and inquiry-based learning. *Educational Psychologist, 41*(2), 75-86.
- Kumar, R. (2018). *Research methodology: A step-by-step guide for beginners*. Sage.
- Kynigos, C. (2015). Constructionism: Theory of learning or theory of design? In *Selected regular lectures from the 12th International Congress on Mathematical Education* (pp. 417-438). Springer, Cham.

- Lederman, N. G., & Lederman, J. S. (2015). What is a theoretical framework? A practical answer. *Journal of Science Teacher Education*, 26(7), 593-597.
- Malin, J. R., Bragg, D. D., & Hackmann, D. G. (2017). College and Career readiness and every Student Succeeds Act. *Educational Administration Quarterly*, 53(5), 809-838.
- Meng, X. (2013, May). Scalable simple random sampling and stratified sampling. In *International Conference on Machine Learning* (pp. 531-539). PMLR.
- Mohajan, H. K. (2017). Two criteria for good measurements in research: Validity and reliability. *Annals of Spiru Haret University. Economic Series*, 17(4), 59-82.
- Mohd Shahali, E. H., Halim, L., Rasul, M. S., Osman, K., & Mohamad Arsad, N. (2019). Students' interest towards STEM: a longitudinal study. *Research in Science & Technological Education*, 37(1), 71-89.
- Mugenda, O. M., & Mugenda, A. G. (2003). *Research methods: Quantitative and Qualitative Approaches*. Nairobi; African Centre for Technology Studies.
- Mwaringa, L. M. (2017). The Impact of Robotics Competitions on the Level of Technology in Institutions of Higher Learning in Kenya. *JKUAT Annual Scientific Conference*.
- Ng, R., Tang, Y., Lin, H., Chu, X., & Au, K. S. (2021, May). Development of a portable hybrid pendubot-acrobot robotic platform for on and off-campus teaching and learning. In *2021 American Control Conference (ACC)* (pp. 98-105). IEEE.
- Njeru, D. N. (2016). *An application for career pathways decision making among high school students: case of Nairobi* (Doctoral dissertation, Strathmore University).
- Ntemngwa, C., & Oliver, S. (2018). The implementation of integrated science technology, Engineering and Mathematics (STEM) instruction using robotics in the middle school science classroom. *International Journal of Education in Mathematics, Science and Technology*, 6(1), 12-40.
- Olamide, S. O., & Olawaiye, S. O. (2013). The factors determining the choice of career among secondary school students. *The International Journal of Engineering and Science*, 2(6), 33-44.
- Olawale, J., Oludele, A., Ayodele, A., & Alejandro, N. M. (2007, November). Development of a microcontroller based robotic arm. In *Proceedings of the 2007 Computer Science and IT Education Conference* (pp. 549-557).
- Papavlasopoulou, S., Giannakos, M. N., & Jaccheri, L. (2019). Exploring children's learning experience in constructionism-based coding activities through design-based research. *Computers in Human Behavior*, 99, 415-427.



- Papert, S. (1972). Teaching children to be mathematicians versus teaching about Mathematics. *International journal of mathematical education in science and technology*, 3(3), 249-262.
- Papert, S. A. (2020). *Mindstorms: Children, computers, and powerful ideas*. Basic books.
- Papert, S., & Harel, I. (1991). Situating constructionism. *Constructionism*, 36(2), 1-11.
- Patten, M. L., & Newhart, M. (2017). *Understanding research methods: An overview of the essentials*. Routledge.
- Phelps, L. A., Camburn, E. M., & Min, S. (2018). Choosing STEM college majors: Exploring the role of pre-college Engineering courses. *Journal of Pre-College Engineering Education Research (J-PEER)*, 8(1), 1.
- Piaget, J. (1964). Cognitive development in children. *Journal of research in science teaching*, 2(2), 176-186.
- Rana, R., & Singhal, R. (2015). Chi-square test and its application in hypothesis testing. *Journal of the Practice of Cardiovascular Sciences*, 1(1), 69.
- Rhind, D., Davis, L., & Jowett, S. (2014). Questionnaires. In *Research methods in sports coaching* (pp. 111-122). Routledge.
- Ritchie, J., Lewis, J., & Elam, G. (2003). Designing and selecting samples. *Qualitative research methods*, 77-108.
- Rocker Yoel, S., Shwartz Asher, D., Schohet, M., & Dori, Y. J. (2020). The Effect of the FIRST Robotics Program on Its Graduates. *Robotics*, 9(4), 84.
- Román-Ibáñez, V., Pujol-López, F. A., Mora-Mora, H., Pertegal-Felices, M. L., & Jimeno-Morenilla, A. (2018). A low-cost immersive virtual reality system for teaching robotic manipulators programming. *Sustainability*, 10(4), 1102.
- Roulston, K. (2011). Working through challenges in doing interview research. *International Journal of Qualitative Methods*, 10(4), 348-366.
- Roulston, K., & Choi, M. (2018). Qualitative interviews. *The SAGE handbook of qualitative data collection*, 233-249.
- Sadler, P. M., Sonnert, G., Hazari, Z., & Tai, R. (2012). Stability and volatility of STEM career interest in high school: A gender study. *Science education*, 96(3), 411-427.
- Salzman, N., & Ohland, M. (2015, October). Effects of pre-college Engineering participation on first-year Engineering outcomes. In *2015 IEEE Frontiers in Education Conference (FIE)* (pp. 1-4). IEEE.
- Saygin, C., Yuen, T. T., Shipley, H. J., & Akopian, D. (2012, June). Design, development, and implementation of educational robotics activities for k-12 students. In *2012 ASEE Annual Conference & Exposition* (pp. 25-404).

- Scaradozzi, D., Sorbi, L., Pedale, A., Valzano, M., & Vergine, C. (2015). Teaching robotics at the primary school: an innovative approach. *Procedia-Social and Behavioral Sciences*, 174, 3838-3846.
- Scaradozzi, D., Cesaretti, L., Screpanti, L., & Mangina, E. (2020). Identification of the students learning process during education robotics activities. *Frontiers in Robotics and AI*, 7, 21.
- Screpanti, L., Cesaretti, L., Marchetti, L., Baione, A., Natalucci, I. N., & Scaradozzi, D. (2018). An educational robotics activity to promote gender equality in STEM education. *ICICTE 2018 Proceedings*.
- Serrezuela, R. R., Chavarro, A. F. C., Cardozo, M. A. T., Toquica, A. L., & Martinez, L. F. O. (2017). Kinematic modelling of a robotic arm manipulator using Matlab. *ARPN Journal of Engineering and Applied Sciences*, 12(7), 2037-2045.
- Shachaf, P. (2008). Cultural diversity and information and communication technology impacts on global virtual teams: An exploratory study. *Information & Management*, 45(2), 131-142.
- Ssegawa, J. K., & Kasule, D. (2017). A self-assessment of the propensity to obtain future employment: a case of final-year Engineering students at the University of Botswana. *European Journal of Engineering Education*, 42(5), 513-532.
- Sullivan, G. M. (2011). A primer on the validity of assessment instruments. *Journal of graduate medical education*, 3(2), 119-120.
- Takacs, A., Eigner, G., Kovács, L., Rudas, I. J., & Haidegger, T. (2016). Teacher's kit: Development, usability, and communities of modular robotic kits for classroom education. *IEEE Robotics & Automation Magazine*, 23(2), 30-39.
- Teddle, C., & Tashakkori, A. (2009). *Foundations of mixed methods research: Integrating quantitative and qualitative approaches in the social and behavioral sciences*. Sage.
- Thomas, B., & Watters, J. J. (2015). Perspectives on Australian, Indian and Malaysian approaches to STEM education. *International Journal of Educational Development*, 45, 42-53.
- Tiryaki, A., & Adigüzel, S. (2021). The Effect of STEM-Based Robotic Applications on the Creativity and Attitude of Students. *Journal of Science Learning*, 4(3), 288-297.
- Tsalmpouris, G., Tsinarakis, G., Gertsakis, N., Chatzichristofis, S. A., & Doitsidis, L. (2021). HYDRA: Introducing a Low-Cost Framework for STEM Education Using Open Tools. *Electronics*, 10(24), 3056.
- Tsoy, T., Sabirova, L., Lavrenov, R., & Magid, E. (2018, September). Master program students' experiences in robot operating system course. In *2018 11th International Conference on Developments in eSystems Engineering (DeSE)* (pp. 186-191). IEEE.

- Vandeveldel, C., Wyffels, F., Ciocci, M. C., Vanderborcht, B., & Saldien, J. (2016). Design and evaluation of a DIY construction system for educational robot kits. *International Journal of Technology and Design Education*, 26(4), 521-540.
- Varpio, L., Paradis, E., Uijtdehaage, S., & Young, M. (2020). The distinctions between theory, theoretical framework, and conceptual framework. *Academic Medicine*, 95(7), 989-994.
- Veselovská, M., & Mayerová, K. (2017, April). LEGO WeDo curriculum for lower secondary school. In *International Conference on Robotics and Education RiE 2017* (pp. 53-64). Springer, Cham.
- Vygotsky, L. S. (1978). Socio-cultural theory. *Mind in society*, 6(3), 23-43.
- Williams, C. (2007). Research methods. *Journal of Business & Economics Research (JBER)*, 5(3).
- Williamson, C. (2013). Questionnaires, individual interviews and focus groups. In *Research methods: Information, systems, and contexts* (pp. 349-372). Tilde University Press.
- Wilson, M., & Okraku-Yirenkyi, Y. (2019). Impact of the Robotics inspired Science Education (RiSE) Program on Education in Ghana. *Journal of Engineering and Economic Development*, 5(2), 11-22.
- Xenakis, A., & Brentas, S. (2019). STEM activities based on educational robotics recyclable materials and Arduino programming. In *EDULEARN19 Proceedings* (pp. 1443-1452).
- Xu, M., Fralick, D., Zheng, J. Z., Wang, B., & Changyong, F. E. N. G. (2017). The differences and similarities between two-sample t-test and paired t-test. *Shanghai archives of psychiatry*, 29(3), 184.
- Yamanoor, N. S., & Yamanoor, S. (2017, October). High quality, low cost education with the Raspberry Pi. In *2017 IEEE Global Humanitarian Technology Conference (GHTC)* (pp. 1-5). IEEE.
- Ziaeeffard, S., Miller, M. H., Rastgaar, M., & Mahmoudian, N. (2017). Co-robotics hands-on activities: A gateway to Engineering design and STEM learning. *Robotics and Autonomous Systems*, 97, 40-50.

## APPENDICES

## **APPENDIX A: LETTER OF INTRODUCTION**

Peter Mwangi Ngugi,  
Department of Education and Technology,  
Murang'a University of Technology,  
P.O. Box Private Bag,  
Thika.  
Dear respondent,

### **RE: DATA COLLECTION**

I am a student of Murang'a University of Technology. Currently I am pursuing a Doctor of Philosophy (PhD) in Technology Education (Electrical and Electronics) in the Department of Education and Technology. As part of the requirement for the reward of the degree, I am undertaking a research on: -

### **IMPACT OF EDUCATIONAL ROBOTIC ACTIVITIES ON SECONDARY SCHOOL STUDENTS' INTEREST IN ENGINEERING CAREER PATHWAYS**

You have been selected as a participant for this study. The study entails exposure to an educational robot, comprising of a robotic car and robotic arm. Afterwards, you are required to respond to a questionnaire. The study will also involve exams on the topics learnt using the robot designs. Please cooperate in all sections of the questionnaire to enhance successful completion of the study. Responses received from you will be handled with extreme confidentiality and only utilized for the purpose of this research. The exam results will not be used for grading purposes, but only within the confines of this research project. Your cooperation is highly appreciated.

Yours sincerely,



Peter Ngugi

## APPENDIX B: INFORMED CONSENT

Dear respondent,

I am a student of Murang'a University of Technology. Currently I am pursuing a Doctor of Philosophy (PhD) in Technology Education in the Department of Education and Technology. As part of the requirement for the reward of the degree, I am undertaking a research on: -

### **IMPACT OF EDUCATIONAL ROBOTIC ACTIVITIES ON SECONDARY SCHOOL STUDENTS' INTEREST IN ENGINEERING CAREER PATHWAYS**

You have been selected as a participant for this study. The study entails exposure to an educational robot, comprising of a robotic car and robotic arm. Afterwards, you are required to respond to a questionnaire. You are requested to feel free to take part in the research and respond to all details required of you in the experiment and the questionnaire. If you have any queries regarding the research, you are free to ask for clarification. Also, you are free to withdraw from the research at any point. No victimization and threats will follow after withdrawal from the study and your decision will be greatly honoured. Ethics of research, including confidentiality, voluntary withdrawal among others will be adhered at all times in the process of data collection, data analysis and any use that the findings of the study may be put into. Your responses will only be used for the intended research only. The data obtained from your responses will form part of my thesis, written papers and published articles as per the requirements of Murang'a University in the future. As part of the requirements of the University a copy of the thesis will be submitted to the library of Murang'a University of Technology. Your support will be highly appreciated.

*Acknowledgement: Please sign this form to show agreement and your willingness to take part in the research.*

**Parent/Guardian** .....

**Signature** ..... **Date**

.....

## APPENDIX C: QUESTIONNAIRE

### **Introduction**

The questionnaire is prepared with the intention gathering general information among secondary school form 2 students on the impact of robots and robotic activities to interest in Engineering career pathways. Please answer the questions by ticking (✓) as appropriate. The responses to the questions will be treated with high level of confidence.

### **PART A: Personal Information**

1. School Category

Girls School

Boys School

Mixed School

2. Gender

Male

Female

### **PART B: Background on Physics and Mathematics activities**

3. How often are Physics and Mathematics classes fun?

Always

Often

Sometimes

Rarely

Never

4. How often have you engaged in activities that aid understanding Physics and Mathematics?

Always

Often

Sometimes

Rarely

Never

5. How often have these activities improved your understanding in Physics and Mathematics

Always

Often

Sometimes

Rarely

Never

### **PART C: Background on Robotics**

6. Have you ever interacted with a robot?

Yes

No

7. If yes for how long?

0-1 week

2-3 weeks

4 weeks and above

### **PART D: Robotic activities**

8. It was fun and enjoyable to undertake the robotics activities

Strongly disagree

Disagree

Neither agree or disagree

Agree

strongly agree

9. The robotic activities gave me practical experience of what to expect in Engineering

Strongly disagree

Disagree

Neither agree or disagree

Agree

strongly agree

agree

10. The robotic activities were interesting and exciting

Strongly disagree  Disagree  Neither agree or disagree  Agree  strongly agree

11. I would carry out the activities with a lot of ease

Strongly disagree  Disagree  Neither agree or disagree  Agree  strongly agree

**PART E Robotic activities integration**

12. The use of robotic activities in learning various topics in Physics and Mathematics aid in understanding the sciences

Strongly disagree  Disagree  Neither agree or disagree  Agree  strongly agree

13. The use of the robotic activities made learning of Physics and Mathematics fun

Strongly disagree  Disagree  Neither agree or disagree  Agree  strongly agree

14. The use of the robotic activities in learning of Physics and Mathematics improved my creativity.

Strongly disagree  Disagree  Neither agree or disagree  Agree  strongly agree

15. The use of the robotic activities in learning of Physics and Mathematics changed improved my attitude towards the subjects.

Strongly disagree  Disagree  Neither agree or disagree  Agree  strongly agree

16. Integration of robots in educational activities could raise the interest of the students in participating in the classroom activities .

Strongly disagree  Disagree  Neither agree or disagree  Agree  strongly agree

17. Educational robotics should be used as a learning object to motivate student's classroom instruction on Physics and Mathematics Education

Strongly disagree  Disagree  Neither agree or disagree  Agree  strongly agree

18. Educational Robotics aid in making difficult concepts easier in Physics and Mathematics as compared to the common laboratories exercises.

Strongly disagree  Disagree  Neither agree or disagree  Agree  strongly agree



**PART F: Impact of robotic activities**

19. In your own opinion, would you say the exposure to robotic car and robotic arm can give you a better understanding of
- a) the science subjects you learn in class  
 To no extent  To a lower extent  To a moderate extent  To a great extent  
 To a very great extent
  - b) What to expect in the Engineering career?  
 To no extent  To a lower extent  To a moderate extent  To a great extent  
 To a very great extent
20. In your own opinion to what extent can the exposure to Engineering through robotic activities change the perception of Physics and Mathematics?  
 To no extent  To a lower extent  To a moderate extent  To a great extent  
 To a very great extent
21. In your own opinion to what extent can the exposure to robotic activities influence your future career pathways?  
 To no extent  To a lower extent  To a moderate extent  To a great extent  
 To a very great extent

**PART G: Career choice**

22. In which Class or Form did you start thinking about your career pathways?  
 Primary  Form 1  Form 2  Not yet
23. I would like to be a scientist when I leave school  
 Yes  No  Not Sure
24. Physics and Mathematics are important to me as I prepare for my future career  
 Yes  No  Not Sure
25. The exposure to educational robotics in learning Physics and Mathematics has an impact in my interest towards Science, Technology, Mathematics and Engineering career  
 Yes  No  Not Sure
26. Indicate the course you would want to pursue after doing your KCSE?  
.....  
...

## APPENDIX D: INTERVIEW

### Introduction

This interview guide is designed to gather general information on the impact of exposure of form 2 students to educational robotics interest in Engineering career pathways. The information obtained will be treated with ultimate confidentiality. Please respond to the questions honestly and diligently following the instructions given.

### **PART A: Exposure to Robotics**

1. Have you ever interacted with educational robots before this workshop? If yes where?

.....  
.....  
.....  
.....

2. In your own opinion how do you think the exposure to educational robotics affect learners understanding of what Engineering is all about?

.....  
.....  
.....

### **PART B: Educational robotics designs**

3. Are the robotic designs (Car and arm) used in this workshop appropriate for teaching and learning of Physics and Mathematics

.....  
.....  
.....

4. In your own opinion how do you think these designs will affect the teaching and learning of Physics and Mathematics?

.....  
.....  
.....

**PART C: Robotic activities and integration to curriculum**

5. What would you say about the suitability of the activities developed from the robotic designs in Physics and Mathematics teaching?

a) In terms of the possibility of splitting the activities into simple tasks

.....  
.....  
.....

b) The nature of the tasks in relation to learners' level

.....  
.....  
.....

c) Ease of integration of the activities

.....  
.....  
.....

d) Whether the activities are hands-on and learner centered

.....  
.....  
.....

6. How would the robotic activities affect the understanding of the various topics in Physics and Mathematics selected in the Form 2 syllabus?

.....  
.....  
.....

7. How would the robotic activities used in teaching Physics and Mathematics affect the learners' creativity?

.....  
.....  
.....

8. How would the robotic activities used in teaching Physics and Mathematics affect the learners' attitudes towards the subjects?

.....  
.....  
.....

9. What effect does the integration of the robotics activities to Physics and Mathematics topics have on learning of the topics and the subjects in general?

.....  
.....  
.....

10. In your own opinion what are the benefits of integrating the robotic activities in the curriculum?

**PART D: Impact of robotic activities and career choice**

11. How does the exposure to the robotics activities affect learners understanding of the Physics and Mathematics?

.....  
.....  
.....

12. How does the exposure to the robotic activities affect learners' perception of Physics and Mathematics?

.....  
.....  
.....

13. In your own opinion what impact would the exposure to educational activities have to learners' career pathways choice?

.....  
.....  
.....

*Thank you for your response & participation*

## APPENDIX E: TESTS FOR PRECOLLEGE SESSIONS

### DAY 1 SECONDARY SCHOOL SESSION PROGRAMME

NAME.....

SCHOOL.....

#### PRETEST EXAM

##### SECTION A

- Which of the following does NOT define a robot?
  - It's a programmable device
  - It is powered by Petroleum products
  - It performs a task on command
  - It is a multi-functional manipulator
- Match the following

<b>Robot part</b>	<b>Function</b>
Gripper	Detecting input from the outside world
Controller	Moving the manipulator and end effector
Sensor	Delivers commands to the actuators
Actuator	For holding a piece or a tool effector
- Which of the following statements describe how Robots perform tasks?
  - According to what is around them
  - They just perform the tasks
  - According to what they have been programmed to do.
  - All of the above.
- Which of the following is equal to 1 Kilobyte (1 KB) ?
  - 1000 bytes
  - 1000 bits
  - 1024 bytes
  - 1000 Mega bytes
- Which of the following is equal to 1000 milliseconds?
  - 0.001 seconds
  - 1 second
  - 0.01 seconds
  - 100 seconds
- Drives in a robot are also known as
  - Actuators
  - Controller
  - Sensors
  - Manipulator
- Which of the following sensors determines the relationship of the robot and its environment and the objects handled by it?
  - Internal State sensors
  - External State sensors
  - Both (A) and (B)
  - None of the above
- What is the name of the information sent from robot sensors to robot controller?
  - Temperature

- B. Pressure
  - C. Feedback
  - D. Signal
9. Which of the following components of a robot unit could be programmed to determine what the robot would do?
- A. Sensor
  - B. Controller
  - C. Gripper
  - D. End effector
10. Which of the following sensors can be used for measuring distance?
- A. Piezoelectric sensor
  - B. Light sensor
  - C. Colour sensor
  - D. Ultrasonic sensor

## SECTION B

11. Determine the length of the black line that represents the pathways to be followed by the robot
12. The robotic arm picks an object and places it in another location and answer the following questions.
- a) Highlight the effect of forces as the arm moves
  
  
  
  
  
  
  
  
  
  
  - b) If the weight of the object picked is 20g and the acceleration of the arm is  $2 \text{ m/s}^2$ , determine force

## DAY TWO PRE-COLLEGE PROGRAMME

NAME.....

SCHOOL.....

### SECTION 1

1. You were asked to create system that controls power in a substation. The system is to work with Arduino and after writing the program, you realize its size is 250kB. What type of Arduino would you choose?
  - A. Arduino Uno
  - B. Arduino Leonardo
  - C. Arduino Mega
  - D. Arduino Lilypad
2. Among the following, which function will run a code in it continuously?
  - A. Void loop ()
  - B. Void setup ()
  - C. Void redo ()
  - D. Void ()
3. Which of the following is NOT a component of a robot?
  - A. Sensor
  - B. Actuator
  - C. Telephone
  - D. Controller
4. Which of the following is statement is NOT true about robots?
  - A. Robots must not be programmed
  - B. Robots are powered by Electricity
  - C. Some robots are autonomous
  - D. Some robots are wheeled
5. Which of the following statement is FALSE?
  - A. Robots can be used in Agriculture
  - B. Robots can be used in mobile industries
  - C. Robots can disobey human beings
  - D. Robots can be used in Hospitals

### SECTION 2

6. Using AUTOCAD draw the following shapes
  - i. A rectangle whose dimensions are 100mm by 150mm
  - ii. A circle whose diameter is 140mm
7. Export the shapes to the 3-D printer and print them.
8. Explain the function of the key components of a robot
9. A line following robot is placed on a line. Estimate the time taken to cover a distance of 5m along
  - a) the curved line
  - b) the straight line

Fill in the following table and estimate the average speed of the robot

<b>Trial</b>	<b>1</b>	<b>2</b>
<b>Estimated time for the curved line (s)</b>		
<b>Estimated time for the straight line (s)</b>		



**DAY 3 PRECOLLEGE SESSION EXERCISE**

**PHYSICS AND MATHEMATICS**

NAME OF THE STUDENT.....

NAME OF THE SCHOOL.....

**PART ONE**

1. Why is it necessary to use motor drivers when driving wheels of a robot?
  - A. To make the robot move any direction.
  - B. To enable control of a high-power motor using a low power microcontroller.
  - C. To make the robot stop instantly when prompted to stop.
  - D. None of the above.
2. Which of the following motors can best be used to control a robot arm?
  - A. Servo motor
  - B. Stepper motor
  - C. Induction DC motor
  - D. Three phase AC induction motor.
3. A student is using Arduino to control a servo motor. Which of the following angles can he not achieve?
  - A. 10°
  - B. 175°
  - C. 170°
  - D. 420°

**PART TWO**

4. A robot needs to stop 30 cm in front of a wall that is 150cm away. How many seconds will the robot take to move in the direction of the wall if it is moving at 0.6m/sec.
5. Speed X time= Distance  
Using a robotic car and the distances moved, complete the following table

Distance	Time in seconds	Speed
50cm		
100cm		
150cm		
200cm		
250cm		

- i) Plot a graph of distance against time and answer the following questions
- ii) What time will it take the robot to move for  
180cm  
220cm

6. Sketch the different angles made by the movement of various motors in a robotic arm

<b>Motor</b>	<b>Approximate degrees</b>	<b>Sketch</b>	<b>Area of the arc</b>
<b>1</b>			
<b>2</b>			
<b>3</b>			
<b>4</b>			

7. Measure the diameter of a robot wheel and answer the following questions  
Determine
- The circumference of the wheel
  - If the robot covers a distance of 300 cm, how many complete revolutions will the robot make?

**APPENDIX F: ROBOTIC ACTIVITIES MANUAL**

**PRIOR EXPOSURE TO ENGINEERING**

**PRECOLLEGE ROBOTIC ACTIVITIES SESSIONS**

**INTEGRATION OF ROBOTIC ACTIVITIES TO**

**PHYSICS AND MATHEMATICS MANUAL**

By Peter N Mwangi 2021

# **SECONDARY SCHOOL ROBOTIC ACTIVITIES**

## **1. Introduction to electricity**

The students will be exposed to various basic concepts in electricity in order to appreciate use of conversion of energy and consumption of the same on various robot parts. Some of the concepts include Electromagnetism: electricity, electrostatics, electric fields, simple circuits, magnetism, magnetic force, magnetic fields, and induction

- Basic circuits: electrical components (resistors, diodes, transistors, capacitors), Ohm's law.

### **Laboratory activities include:**

- Mounting the components on the breadboard
- Measuring voltage, resistance, and current in simple circuits to verify ohm's law.

## **Solar energy**

The students will be exposed to the basics of solar photovoltaic principle.

- Solar Panels-Measurement of current voltage
- Application in robotics

## **2. Sound Waves.**

In this activity, students explore sound waves. Specifically, they use a sound sensor to explore a sound wave's intensity by designing experiments to investigate the variables that affect the measurement of a sound wave's loudness. For example, students explore variables such as the distance between sound source and microphone, sound wave direction and shape (approximated by a cone or sphere), the frequency response of the microphone, and the conductivity of sound through different media.

By the end of the session the Student should be able to

- Describe sound waves in terms of a transfer of energy
- Measure the loudness of a sound wave and relate this measurement to a wave's amplitude, energy, power, and intensity.
- Use the ultrasonic sensor in the robot for purposes of measurement of distance

## **3. 3D design and printing**

The students will be introduced to AUTOCAD to learn how to draw basic shapes.

By the end of the session the Student should be able to

- to draw shapes like square, rectangle, circle and extrude.
- to print these basic shapes using a 3D printer.

## **4. Robotics**

### **Introduction**

By the end of the sessions the Students should be able to

- Identify the various parts of a robot
- Analyze the relationships between force, mass, gravity, and the motion of objects with the help of the robot.

### **Activities**

- Identifying parts of a robot
- Using the robot in Calculation of average velocity, instantaneous velocity, and acceleration in a given frame of reference.
- Compare graphically and algebraically the relationships among position, velocity, acceleration, and time.
- Measure and calculate the magnitude of frictional forces and Newton's three Laws of Motion.
- Measure and calculate the magnitude of gravitational forces.
- Measure and calculate two-dimensional motion (projectile and circular) by using component vectors.
- Measure and calculate centripetal force.
- Determine the conditions required to maintain a body in a state of static equilibrium.

### **5. Robot Assembly**

The students will identify different parts of a multifunctional car which has functions line tracking and obstacle avoidance.

#### **Objectives**

By the end of the exercise the learner should be able to

- Identify different parts of the robot for instance the motors, tracking module, Sensors, Arduino microcontroller.
- Assemble the parts to constitute a robot

#### **Procedure of demonstrating the assembly process.**

- Motor installation- Fixing the motor and motor drive board.
- Installation of the tracking module under the chassis front
- Fixing of the Arduino board and the battery box on the board
- Assembling the holder, and the ultrasonic module
- Testing the module

### **6. The Microcontroller**

#### **Activities**

- Familiarization with the Arduino microcontroller set-up and operation including menus, buttons, opening and saving new programs.

#### **Introduction**

- Arduino is an open source platform.
- It has a flexible, easy to use hardware and software.

#### **Objectives**

It is expected that after the exercise that students should be able to:

- Apply Microcontroller users interface and be able to demonstrate basic utilities such as opening a new programme, saving, checking and uploading programs
- Do some simple programmes to control LED, sensors and motors.

### **7. Application of robot activities**

## Line Tracking

**Step 1:** Programme the tracking sensor.

**Step 2** Prepare a black track of width 25mm on the block board provided.

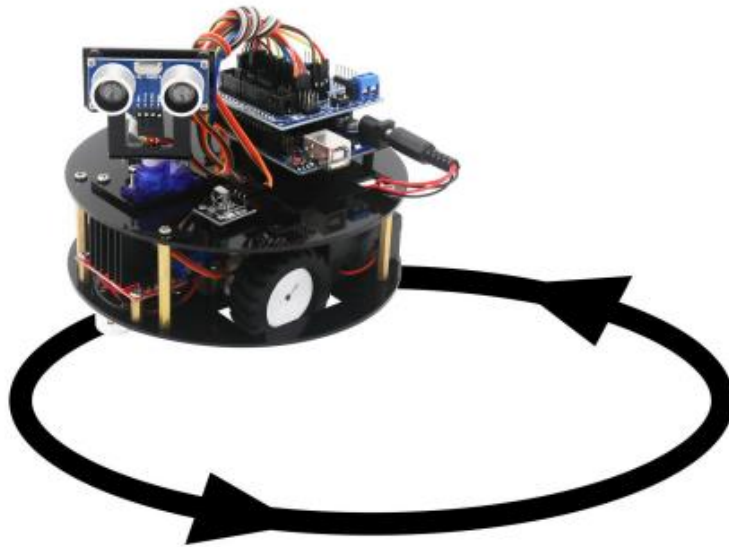
**Step 3:** Adjust the sensitivity of tracking sensor modules.

Turn on and hold the car to adjust the potentiometer on the tracking sensor, the signal indicate LED light will turn on when sensor is above reflecting surface, and the signal LED will turn off when the sensor is above black track.

Signal Indicate LED ON: reflecting surface.

Signal Indicate LED OFF: Black Track

**Step 4:** Turn on the car and put the car over the black track, then the car will move along the black track.



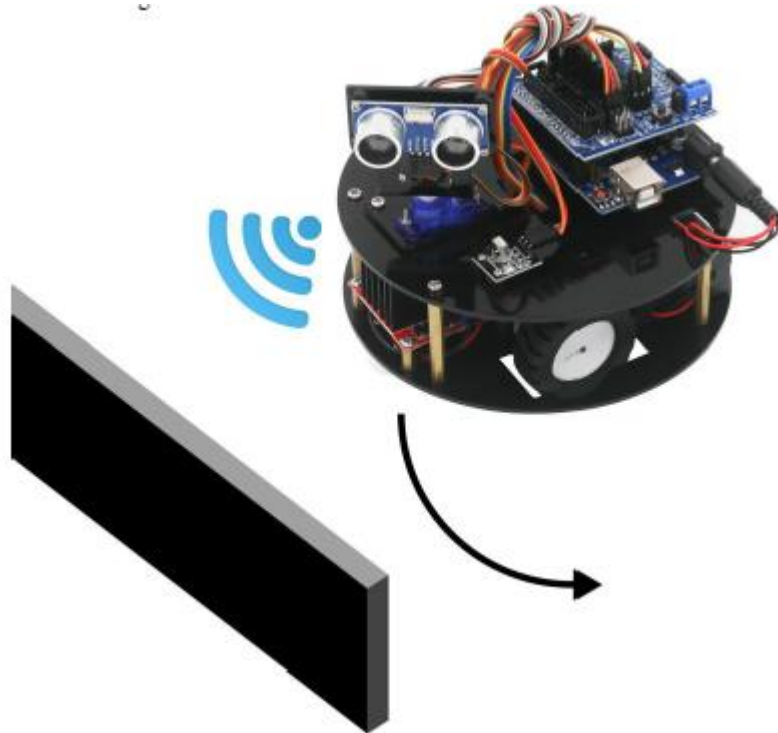
## Obstacle Avoidance

### Activity

This lesson, regarding Arduino as main control, detect front obstacle by ultrasonic sensor and platform motor, and send the feedback to Arduino.

Arduino will analyse the feedback signal and then control the driver motor to adjust the car diversion.

Finally the car is able to avoid obstacle automatically and keep going. In addition, you can observe the state and speed of the car, the angle of motor, and the distance between car and obstacle through 1602 I2C Module.



**Principle:**

1. Ultrasonic detecting distance: one port emits high level more than 10 US. Once it outputting level, open potentiometer to time. When the port becomes low level, read out current value. Use the time of detecting distance to calculate distance.
2. Use ultrasonic to detect the distance between obstacle and car, so that control the motion of the car according to the data.
3. If the distance between the car and obstacle is less than 35 cm, the car goes backward; if the distance is no less than 10 cm, the car goes forwards; if the distance is less than 60 cm , the motor turns to detect the distance between car and left obstacle or right obstacle; if the distance between car and left obstacle, the distance between car and right obstacle are less than 35 cm, the car goes backward; if the distance between car and left obstacle is larger , the car turns left; if the distance between car and left obstacle is less than or equal to the distance between car and right obstacle, the car turns right.

**8. Testing Speed and acceleration of the robotic Cars.**

Students work in a team to figure out Speed or Acceleration. The students use a rotation sensor to measure distance, speed, and acceleration of their car.

The learning objectives for this project are to:

- Describe motion in terms of speed and acceleration.
- Compare various factors that may affect speed and acceleration of an object including power, time of travel, gear ratio and wheel size.
- Utilize a scientific experiment to inform the Engineering design process with the goal of maximizing acceleration and speed.

To achieve these objectives a measuring tool is employed to calculate the length of a pathways and a stopwatch to measure the time needed by the robot to follow it.

Once the students had captured data about space and time, they easily derived the robot speed. The information was then employed to predict the robot's travel time along a straight pathways or to measure the length of different surfaces, by applying the inverse formulas of the uniform rectilinear motion.

The students will then be asked to implement a program to compute the speed and acceleration of the robot through the radius of wheels and the number of rotations of an engine. The robot was programmed using specific variables (in this case, the time and the number of rotations

## **9. Force and Motion using robots**

### **Concepts**

The relationships between the different laws of force and motion and their impact on objects, including key factors such as; acceleration, inertia, mass, momentum, friction, speed, balanced and unbalanced forces

### **Objectives**

It is expected that by the end of the exercise students should be able to:

- Demonstrate understanding of the different laws of force and motion and their impact on objects.

## **10. Gear Ratios; Speed and Torque**

### **Concepts**

- Calculating gear ratios in multiple gear systems.
- Determining vehicle speed
- Gain an understanding of how changing gear ratios effects force (torque) and motion (speed) and their interrelationships with one another

### **Objectives**

It is expected that students by the end of the exercise should be able to:

- Calculate the ratio of one of gear set, and mathematically determine its effects on force (torque) and motion (speed), and will validate calculations with tachometer and torque meter
- Calculate the ratio of a second gear set, and mathematically determine their effects on force (torque) and motion (speed), and compare the results to the first study above
- Calculate the robot speed using revolutions-per-minute (RPM), tire diameter and circumference
- Explain the functioning of a servomotor and how it can be used in robotics.

### **Newton's law, momentum, force, equilibrium, free body diagrams, work, energy**

- 3-D modeling of designs (programs similar to AutoCAD or SolidWorks should be used): basic modeling of components, drafting

Possible lab activities include:



- Measuring the torque of a motor
- Building a truss bridge out of balsa wood to support the maximum weight
- Building a mousetrap car to go the maximum distance forward

### **11. Robotic arm activities**

By the end of the session the students should be able

- Identify different parts of the arm
- Explain the functions of the different components of the arm
- Programme a servomotor to move at different degrees

#### **Activities**

- Identify angles made by each motor as the arm picks a block and places it at a different location
- Calculate the angle of rotation and identify the position of the object and the image.

### APPENDIX G: BUDGET

Items	Qty	Cost/Unit(Kshs)	Year 1	Year 2	Year 3
Concept printing and binding	3	1,000	3,000		
Printing and binding of Proposal	3	5,000	15,000		
Transport and Accommodation			20,000	50,000	70,000
Laptop	1	50,000		50,000	
Robotics Assembly and other workshop requirements				100,000	
Instrument development and Validation				30,000	
Data Collection				100,000	
Data Analysis					100,000
Publications	4	40,000		80,000	80,000
Thesis Printing and binding	1	40,000			40,000
Internet Bundles			10,000	10,000	10,000
Conferences and seminars Facilitation				60,000	150,000
<b>YEARLY SUB-TOTALS</b>			48,000	480,000	450,000
<b>GRAND TOTAL</b>			978,000		

## APPENDIX H: ROBOTIC ARM PROGRAMME

```
#include <Servo.h>
const int delayTime = 10;
class Servos
{
protected:
  Servo baseServo;
  Servo armServo;
  Servo handServo;
  Servo gripServo;
public:
  void baseWrite(int angle);
  void armWrite(int angle);
  void handWrite(int angle);
  void gripWrite(int angle);
};
void Servos::baseWrite(int angle)
{
  int currentAngle = baseServo.read();
  if(angle < currentAngle)
  {
    for(int i = currentAngle;i > angle;i --)
    {
      baseServo.write(i);
      delay(delayTime);
    }
  }
  else if(angle > currentAngle)
  {
    for(int i = currentAngle;i < angle; i ++)
    {
      baseServo.write(i);
      delay(delayTime);
    }
  }
}
void Servos::armWrite(int angle)
{
  int currentAngle = armServo.read();
  if(angle < currentAngle)
  {
    for(int i = currentAngle;i > angle;i --)
    {
      armServo.write(i);
      delay(delayTime);
    }
  }
}
```

```

    }
  }
  else if(angle > currentAngle)
  {
    for(int i = currentAngle;i < angle; i ++)
    {
      armServo.write(i);
      delay(delayTime);
    }
  }
}
void Servos::handWrite(int angle)
{
  int currentAngle = handServo.read();
  if(angle < currentAngle)
  {
    for(int i = currentAngle;i > angle;i --)
    {
      handServo.write(i);
      delay(delayTime);
    }
  }
  else if(angle > currentAngle)
  {
    for(int i = currentAngle;i < angle; i ++)
    {
      handServo.write(i);
      delay(delayTime);
    }
  }
}
void Servos::gripWrite(int angle)
{
  int currentAngle = gripServo.read();
  if(angle < currentAngle)
  {
    for(int i = currentAngle;i > angle;i --)
    {
      gripServo.write(i);
      delay(delayTime);
    }
  }
  else if(angle > currentAngle)
  {
    for(int i = currentAngle;i < angle; i ++)
    {

```

```

    gripServo.write(i);
    delay(delayTime);
}
}
}
class motion:public Servos
{
private:
void pick()
{
    armWrite(50);
    gripWrite(0);
    armWrite(0);
    handWrite(30);
}
void carry()
{
    baseWrite(90);
}
void drop()
{
    handWrite(0);
    armWrite(50);
    gripWrite(90);
}
void raiseArm()
{
    armWrite(0);
    handWrite(30);
}
void back()
{
    baseWrite(0);
}
public:
void Pick()
{
    pick();
    carry();
    drop();
}
void Reset()
{
    raiseArm();
    back();
}
}

```

```
}servoArm;
class startup:public Servos
{
public:
void configure()
{
    baseServo.attach(2);
    armServo.attach(3);
    handServo.attach(4);
    gripServo.attach(5);
}
}configuration;
void setup()
{
    configuration.configure();
}
void loop()
{
    servoArm.Pick();
    delay(1000);
    servoArm.Reset();
}
```

## APPENDIX I: OBSTACLE AVOIDANCE PROGRAMME

```
#include <Servo.h>
Servo sensorServo;
const int triggerPin = 9;
const int echoPin = 10;
const int servoPin = 8;
const int motor1Pin1 = 2;//Left motor;
const int motor1Pin2 = 3;//Left motor;
const int motor2Pin1 = 4;
const int motor2Pin2 = 5;
const int motor1Speed = 6;
const int motor2Speed = 7;
class motion
{
public:
void foward();
void backward();
void brakes();
void fowardLeft();
void backwardLeft();
void fowardRight();
void backwardRight();
void Speed(int velocity);
}robotMotion;
void motion::foward()
{
digitalWrite(motor1Pin1,HIGH);
digitalWrite(motor1Pin2,LOW);
digitalWrite(motor2Pin1,HIGH);
digitalWrite(motor2Pin2,LOW);
}
void motion::backward()
{
digitalWrite(motor1Pin1,LOW);
digitalWrite(motor1Pin2,HIGH);
digitalWrite(motor2Pin1,LOW);
digitalWrite(motor2Pin2,HIGH);
}
void motion::brakes()
{
digitalWrite(motor1Pin1,LOW);
digitalWrite(motor1Pin2,LOW);
digitalWrite(motor2Pin1,LOW);
digitalWrite(motor2Pin2,LOW);
}
void motion::fowardLeft()
{
```

```

digitalWrite(motor1Pin1,LOW);
digitalWrite(motor1Pin2,LOW);
digitalWrite(motor2Pin1,HIGH);
digitalWrite(motor2Pin2,LOW);
}
void motion::backwardLeft()
{
digitalWrite(motor1Pin1,LOW);
digitalWrite(motor1Pin2,LOW);
digitalWrite(motor2Pin1,LOW);
digitalWrite(motor2Pin2,HIGH);
}
void motion::fowardRight()
{
digitalWrite(motor1Pin1,HIGH);
digitalWrite(motor1Pin2,LOW);
digitalWrite(motor2Pin1,LOW);
digitalWrite(motor2Pin2,LOW);
}
void motion::backwardRight()
{
digitalWrite(motor1Pin1,LOW);
digitalWrite(motor1Pin2,HIGH);
digitalWrite(motor2Pin1,LOW);
digitalWrite(motor2Pin2,LOW);
}
class Sensor
{
protected:
void setServo()
{
sensorServo.attach(servoPin);
}
void setSensor()
{
pinMode(triggerPin,OUTPUT);
pinMode(echoPin,INPUT);
}
private:
long distance()
{
digitalWrite(triggerPin,LOW);
delayMicroseconds(2);
digitalWrite(triggerPin,HIGH);
delayMicroseconds(10);
return duration() /58.2;
}
long duration()
{

```



```

    return pulseIn(echoPin,HIGH);
}
public:
long checkFoward()
{
    sensorServo.write(90);
    return distance();
}
long checkLeft()
{
    sensorServo.write(0);
    return distance();
}
long checkRight()
{
    sensorServo.write(180);
    return distance();
}
};
class startup:public Sensor
{
private:
void setMotors()
{
    pinMode(motor1Pin1,OUTPUT);
    pinMode(motor1Pin2,OUTPUT);
    pinMode(motor2Pin1,OUTPUT);
    pinMode(motor2Pin2,OUTPUT);
}
public:
void configure()
{
    setServo();
    setSensor();
    setMotors();
}
}configuration;
void setup()
{
    configuration.configure();
}
void loop()
{
    beginLoop::
    Sensor sensor;
    if(sensor.checkFoward() > 19)
    {
        robotMotion.foward();
    }
}

```

```
else
{
  robotMotion.brakes();
  delay(500);
  robotMotion.backward();
  delay(1000);
  robotMotion.brakes();
  if(sensor.checkLeft() > 19)
  {
    robotMotion.fowardLeft();
    delay(500);
    goto beginLoop;
  }
  else if(sensor.checkRight() > 19)
  {
    robotMotion.fowardRight();
    delay(500);
    goto beginLoop;
  }
}
}
```

## APPENDIX J: PROGRAMME FOR THE LINE FOLLOWING FUNCTION

```
const int sensor1Pin = 9;
const int sensor2Pin = 6;
const int sensor3Pin = 11;
const int motor1Pin1 = 4;
const int motor1Pin2 = 3;
const int motor2Pin1 = 8;
const int motor2Pin2 = 7;
const int motor1Speed = 5;
const int motor2Speed = 10;
unsigned char sensor1Value;
unsigned char sensor2Value;
unsigned char sensor3Value;
class Sensor
{
protected:
void readSensors()
{
sensor1Value = digitalRead(sensor1Pin);
sensor2Value = digitalRead(sensor2Pin);
sensor3Value = digitalRead(sensor3Pin);
}
};
class Motion:public Sensor
{
protected:
void forward()
{
digitalWrite(motor1Pin1,HIGH);
digitalWrite(motor1Pin2,LOW);
digitalWrite(motor2Pin1,HIGH);
digitalWrite(motor2Pin2,LOW);
}
void right()
{
digitalWrite(motor1Pin1,LOW);
digitalWrite(motor1Pin2,LOW);
digitalWrite(motor2Pin1,HIGH);
digitalWrite(motor2Pin2,LOW);
}
void left()
{
digitalWrite(motor1Pin1,HIGH);
digitalWrite(motor1Pin2,LOW);
digitalWrite(motor2Pin1,LOW);
```

```

    digitalWrite(motor2Pin2,LOW);
}
void brakes()
{
    digitalWrite(motor1Pin1,LOW);
    digitalWrite(motor1Pin2,LOW);
    digitalWrite(motor2Pin1,LOW);
    digitalWrite(motor2Pin2,LOW);
}
void Speed(int speedValue)
{
    analogWrite(motor1Speed,speedValue);
    analogWrite(motor2Speed,speedValue);
}
};
class Manager:public Motion
{
public:
void Manage()
{
    readSensors();
    Speed(255);
    if(sensor1Value == LOW && sensor2Value == LOW && sensor3Value ==
LOW)
    {
        brakes();
    }
    else if(sensor1Value == LOW && sensor2Value == HIGH && sensor3Value ==
LOW)
    {
        forward();
    }
    else if(sensor1Value == LOW && sensor3Value == HIGH)
    {
        left();
    }
    else if(sensor1Value == HIGH && sensor3Value == LOW)
    {
        right();
    }
}
};
class configureClass
{
public:
void configure()

```

```
{
  pinMode(sensor1Pin,INPUT);
  pinMode(sensor2Pin,INPUT);
  pinMode(sensor3Pin,INPUT);
  pinMode(motor1Pin1,OUTPUT);
  pinMode(motor1Pin2,OUTPUT);
  pinMode(motor2Pin1,OUTPUT);
  pinMode(motor2Pin2,OUTPUT);
  pinMode(motor1Speed,OUTPUT);
  pinMode(motor2Speed,OUTPUT);
}
};
void setup()
{
  Serial.begin(9600);
  configureClass configurationManager;
  configurationManager.configure();
}
void loop()
{
  Manager taskManager;
  taskManager.Manage();
}
```

# APPENDIX K1: SAMPLE ROBOTIC TEST 1 ON ACTIVITIES

PRIOR EXPOSURE TO ENGINEERING (PRECOLLEGE SESSION)

SECONADARY SCHOOL STUDENTS

PHYSICS AND MATHEMATICS

NAME OF THE STUDENT.....

NAME OF THE SCHOOL..... Kibutha gic.....

8/10

1) Define the following terms

a. Mass

Mass is the quantity of matter in an object.

b. Force

Force is a pull or a push of an object.

c. Torque

2) How does the mass of a robot affect the amount of power a robot would need?

The higher the mass in an object the higher the rate of power needed by the robot.

3) How does the mass of a robot affect the amount of force needed;

a. To move it?

The higher the mass of an object, the higher the force needed to move it.

b. To move or pick up another object?

The higher the mass of an object, the higher the force needed to move or pick up another object.

4) What kinds of tasks could a robot do that require it to do work?

- > In military activities
- > In agricultural field eg picking fruits
- > In hospitals

3) Speed X time = Distance

Using a robotic car and the distances moved, complete the following table

Distance	Time in seconds	Speed
50cm	2.19	100
100cm	3.94	394
150cm	7.90	161.79
200cm	9.34	241.24
250cm	12.78	

= 31.54 base

= 22 182 / 219  
= 2575 / 197

Handwritten calculations for speed:  $100 / 2.19 = 45.66$ ,  $394 / 3.94 = 100$ ,  $161.79 / 7.90 = 20.48$ ,  $241.24 / 9.34 = 25.83$ ,  $25000 / 12.78 = 1955.39$

## APPENDIX K2: SAMPLE ROBOTIC TEST 2 ON ACTIVITIES

PRIOR EXPOSURE TO ENGINEERING (PRECOLLEGE SESSION)

SECONDARY SCHOOL STUDENTS

PHYSICS AND MATHEMATICS

NAME OF THE STUDENT ~~XXXXXXXXXX~~.....

NAME OF THE SCHOOL KANGEMA HIGH.....

10  
-----  
10

1) Define the following terms

a. Mass - This is the quantity of matter in a body.

b. Force - This is a pull or push of a body.

c. Torque - This is a type of force that makes a body to turn.

2) How does the mass of a robot affect the amount of power a robot would need?  
When the mass is more the power needed would be greater.

3) How does the mass of a robot affect the amount of force needed;

a. To move it?

If the mass of the Robot is more the force needed to move it would be high.

b. To move or pick up another object?

When the mass of the Robot is more the force needed to pick up another object would be greater.

4) What kinds of tasks could a robot do that require it to do work?

Cleaning houses  
Picking up objects

5) Speed X time = Distance

Using a robotic car and the distances moved, complete the following table

Distance	Time in seconds	Speed
50cm	2 sec	0.06 m/s
100cm	9 sec	0.06 m/s
150cm	13 sec	0.1 m/s
200cm	9 sec	0.2 m/s
250cm	11 sec	0.3 m/s

$T = 28 \text{ sec}$

$D = 312 \text{ cm}$

$312 \text{ cm} = 28 \text{ sec}$

$80 \times 28 = 2240$

$312 \times 28 = 8736$

$8736 - 2240 = 6496$

$6496 / 28 = 232$

$\Rightarrow 175.39$

$39$

$190$

## **APPENDIX L: PUBLICATIONS**

- Mwangi, P N, Muriithi, C M, & Agufana, P.B. (2022). INTEGRATION OF ROBOTIC ACTIVITIES IN STEM AND ITS EFFECT TO STUDENTS' PERCEPTION OF THE SUBJECTS. *International Journal of Novel Research in Education and Learning*, 9(4), 82–90.  
<https://doi.org/10.5281/zenodo.7016736>
- Mwangi, P. N., Muriithi, C. M., & Agufana, P.B (2022). Development of Educational Robotics Activities for Secondary School Students to Promote Interest in Engineering Career Path. In *International Journal of Soft Computing and Engineering* (Vol. 12, Issue 3, pp. 12–19). Blue Eyes Intelligence Engineering and Sciences Engineering and Sciences Publication - BEIESP.  
<https://doi.org/10.35940/ijsce.c3580.0712322>
- Mwangi, P. N., Muriithi, C. M., & Agufana, P. B. (2022). Exploring the benefits of Educational Robots in STEM Learning: A Systematic Review. In *International Journal of Engineering and Advanced Technology* (Vol. 11, Issue 6, pp. 5–11). Blue Eyes Intelligence Engineering and Sciences Engineering and Sciences Publication - BEIESP. <https://doi.org/10.35940/ijeat.f3646.0811622>



## APPENDIX M: LETTER OF PERMISSION TO COLLECT DATA



MURANG'A UNIVERSITY OF TECHNOLOGY (MUT)

Tel: +254-771463515

Email: [bps@mut.ac.ke](mailto:bps@mut.ac.ke)

Website: [www.mut.ac.ke](http://www.mut.ac.ke)

P.O.Box 75-10200

Murang'a

DIRECTORATE OF POSTGRADUATE STUDIES

Ref: MUT/RL/PGS/14/2020/VOL.1

Date: 20<sup>th</sup> April 2021

Dear Mr. Mwangi Peter Ngugi [TE500/5068/2018],

RE: APPROVAL OF RESEARCH PROPOSAL AND SUPERVISORS

I am pleased to inform you that the directorate of Postgraduate Studies on the 13<sup>th</sup> April 2021 considered and approved your PhD proposal entitled "The impact of educational robots on pre-college student's interest to engineering career path in Kenya" and appointed the following as supervisors:

1. Prof. Christopher Maina [School of Engineering Technology]
2. Dr. Peace Agufana [School of Education]

You may now proceed with your data collection subject to obtaining research permit from NACOSTI, if required. You should also begin consulting your supervisors and submit through them quarterly progress reports to the Director Postgraduate Studies through your COD and School Dean. Progress Reports can be accessed in the University Website.

It is the policy and regulations of the University that you observe deadlines. The Guidelines on Postgraduate supervision can be accessed in the post graduate Handbook.

Your responsibilities as a student will include, among others;




MUT IS ISO 9001:2015 CERTIFIED

- I. Maintain regular consultation with your supervisor(s), at least once a month
- II. Submit quarterly reports on time, through your supervisors, COD, Dean and to the Director of Postgraduate studies;
- III. Ensure quality work all through;
- IV. Present your research findings at 2- 3 seminars/conferences prior to thesis examination.
- V. Publish one article from your research findings in a refereed journal prior to thesis examination

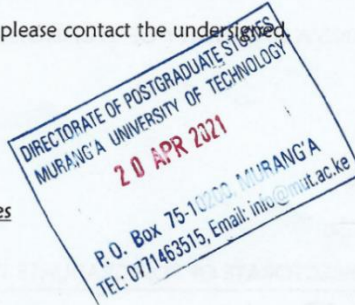
For any further clarification, please contact the undersigned.

Yours Sincerely,




**Prof. Geoffrey Muchiri**  
**Director, Postgraduate Studies**

Cc  
Registrar- (ASA)




MUT IS ISO 9001:2015 CERTIFIED

**APPENDIX N: RESEARCH PERMIT**



**REPUBLIC OF KENYA**  
NATIONAL COMMISSION FOR SCIENCE, TECHNOLOGY AND INNOVATION

Ref No: **416763**



**NATIONAL COMMISSION FOR SCIENCE, TECHNOLOGY & INNOVATION.**

Date of Issue: **09/August/2021**

**RESEARCH LICENSE**



**This is to Certify that Mr.. Peter Ngugi Mwangi of Murang'a University of Technology, has been licensed to conduct research in Murang'a on the topic: THE IMPACT OF EDUCATIONAL ROBOTS ON PRE-COLLEGE STUDENTS' INTEREST TO ENGINEERING CAREER PATH IN KENYA for the period ending : 09/August/2022.**

License No: **NACOSTI/P/21/42293**

416763

*Walter Kimani*

**Applicant Identification Number**

**Director General**

**NATIONAL COMMISSION FOR SCIENCE, TECHNOLOGY & INNOVATION**

**Verification QR Code**



**NOTE: This is a computer generated License. To verify the authenticity of this document, Scan the QR Code using QR scanner application.**